



**RE**

SERIES HYDRAULIC MOTORS

# RE

## OVERVIEW

RE Series motors offer the perfect compromise between price and performance by producing work horse power at a reasonable cost. Although these motors perform well in a wide range of applications, they are especially suited for low flow, high pressure applications. During startup, pressure causes the balance plate to flex toward the rotor, vastly improving volumetric efficiency. As the motor reaches operating pressure, the balance plate relaxes, allowing the rotor to turn freely which translates into higher mechanical efficiencies. Transmitting this power to the output shaft is the most durable drive link in its class. Four bearing options, combined with standard mounting flanges and output shafts, allow the motor to be configured to suit nearly any application.

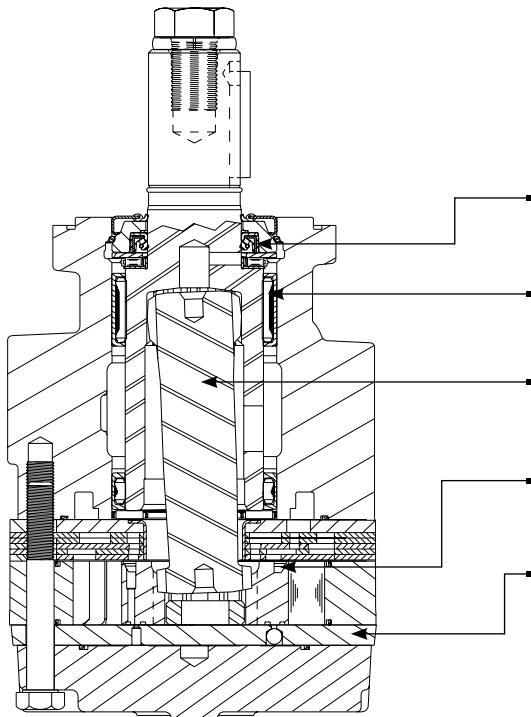

### KEY FEATURES

- **High Pressure Shaft Seal** offers superior seal life and performance and eliminates need for case drain.
- **Three Bearing Options** allow load carrying capability of motor to be matched to application.
- **Heavy-Duty Drive Link** is the most durable in its class and receives full flow lubrication to provide long life.
- **Valve-In-Rotor Design** provides cost effective, efficient distribution of oil and reduces overall motor length.
- **Pressure-Compensated Balance Plate** improves volumetric efficiency at low flows and high pressure.

### SPECIFICATIONS

Intermittent Ratings - 10% of Operation    Peak Ratings - 1% of Operation

CODE	Displacement cc [in <sup>3</sup> /rev]	Max. Speed rpm		Max. Flow lpm [gpm]		Max. Torque Nm [lb-in]		Max. Pressure bar [psi]		
		cont.	inter.	cont.	inter.	cont.	inter.	cont.	inter.	peak
120	121 [7.4]	360	490	45 [12]	61 [16]	327 [2900]	383 [3400]	207 [3000]	241 [3500]	276 [4000]
160	162 [9.9]	370	470	61 [16]	76 [20]	475 [4200]	542 [4800]	207 [3000]	241 [3500]	276 [4000]
200	204 [12.4]	300	370	68 [18]	83 [22]	542 [4800]	633 [5600]	207 [3000]	241 [3500]	276 [4000]
230	232 [14.2]	260	320	68 [18]	83 [22]	644 [5700]	712 [6300]	207 [3000]	241 [3500]	276 [4000]
260	261 [15.9]	260	350	76 [20]	91 [24]	712 [6300]	791 [7000]	207 [3000]	241 [3500]	276 [4000]
300	300 [18.3]	250	320	83 [22]	95 [25]	825 [7300]	938 [8300]	207 [3000]	241 [3500]	276 [4000]
350	348 [21.2]	220	270	83 [22]	95 [25]	921 [8150]	1045 [9250]	207 [3000]	241 [3500]	276 [4000]
375	375 [22.8]	200	250	76 [20]	91 [24]	1006 [8900]	1158 [10250]	207 [3000]	241 [3500]	276 [4000]
470	465 [28.3]	160	200	76 [20]	91 [24]	1096 [9700]	1184 [10475]	172 [2500]	189 [2750]	207 [3000]
540	536 [32.7]	140	170	76 [20]	91 [24]	983 [8700]	1243 [11000]	138 [2000]	172 [2500]	207 [3000]
750	748 [45.6]	100	130	76 [20]	91 [24]	1062 [9400]	1237 [10950]	103 [1500]	121 [1750]	138 [2000]



**120**

Pressure - bars [psi]								Max. Cont.	Max. Inter.
17 [250]	35 [500]	69 [1000]	104 [1500]	138 [2000]	173 [2500]	207 [3000]	241 [3500]		

121 cc [7.4 in<sup>3</sup>/rev.]

Torque - Nm [lb-in], Speed rpm Intermittent Ratings - 10% of Operation

Flow - lpm [gpm]	2 [0.5]	21 [187] 14	51 [448] 13	97 [859] 11	140 [1239] 8					Theoretical rpm	
	4 [1]	24 [215] 26	54 [474] 25	111 [986] 25	162 [1429] 20	225 [1991] 13					16
	8 [2]		57 [500] 58	118 [1043] 53	176 [1554] 51	226 [1997] 44	271 [2400] 40	302 [2673] 35	343 [3036] 27		32
	15 [4]		54 [479] 111	116 [1030] 106	186 [1642] 97	237 [2094] 93	278 [2459] 89	335 [2964] 85	359 [3179] 79		63
	23 [6]		49 [433] 174	116 [1023] 167	168 [1483] 155	232 [2051] 150	279 [2467] 144	328 [2903] 139	360 [3185] 137		125
	30 [8]			111 [984] 245	169 [1497] 214	223 [1973] 205	283 [2505] 200	326 [2884] 197	385 [3404] 188		188
	38 [10]			104 [923] 294	166 [1469] 281	218 [1930] 269	272 [2411] 261	325 [2878] 250	385 [3404] 242		250
	45 [12]			99 [872] 358	161 [1428] 344	217 [1918] 331	276 [2444] 326	321 [2839] 321	385 [3403] 304		313
	53 [14]			91 [807] 415	155 [1372] 413	208 [1845] 398	267 [2363] 391	338 [2992] 369			375
	61 [16]			84 [745] 487	145 [1283] 475	211 [1864] 457	272 [2403] 447	327 [2897] 427			438
											500

Overall Efficiency - 70 - 100%  40 - 69%  0 - 39%

Theoretical Torque - Nm [lb-in]

33 [295]	67 [589]	133 [1178]	200 [1768]	266 [2357]	333 [2946]	399 [3535]	466 [4124]
----------	----------	------------	------------	------------	------------	------------	------------

Displacement tested at 54°C [129°F] with an oil viscosity of 46cSt [213 SUS]

**160**

Pressure - bars [psi]								Max. Cont.	Max. Inter.
17 [250]	35 [500]	69 [1000]	104 [1500]	138 [2000]	173 [2500]	207 [3000]	241 [3500]		

162 cc [9.9 in<sup>3</sup>/rev.]

Torque - Nm [lb-in], Speed rpm Intermittent Ratings - 10% of Operation

Flow - lpm [gpm]	2 [0.5]	37 [326] 7	77 [685] 3	149 [1323] 3	223 [1977] 3	310 [2741] 2	349 [3088] 1			Theoretical rpm	
	4 [1]	30 [264] 21	80 [704] 18	164 [1448] 17	244 [2158] 16	324 [2865] 14	378 [3344] 13	442 [3909] 9			12
	8 [2]	36 [317] 45	80 [711] 43	161 [1423] 41	242 [2143] 39	316 [2792] 37	379 [3350] 35	481 [4258] 32	551 [4880] 28		24
	15 [4]	39 [342] 92	75 [664] 90	171 [1510] 86	253 [2241] 84	321 [2838] 82	379 [3351] 80	451 [3992] 76	516 [4569] 72		47
	23 [6]		71 [631] 138	158 [1395] 134	235 [2078] 131	317 [2806] 127	389 [3447] 122	462 [4088] 121	518 [4586] 118		94
	30 [8]		67 [596] 186	164 [1449] 182	236 [2090] 179	312 [2760] 173	385 [3411] 170	456 [4033] 167	513 [4537] 163		140
	38 [10]		72 [640] 232	149 [1323] 230	234 [2074] 229	309 [2736] 222	376 [3329] 220	455 [4022] 213	522 [4623] 207		187
	45 [12]		67 [596] 279	144 [1275] 279	226 [1998] 272	304 [2689] 270	369 [3270] 264	440 [3890] 255	497 [4397] 247		234
	53 [14]			135 [1190] 326	228 [2022] 323	310 [2739] 317	375 [3317] 311	457 [4040] 304	541 [4789] 299		280
	61 [16]			123 [1087] 372	213 [1889] 372	298 [2634] 364	368 [3253] 361	435 [3847] 357	502 [4439] 350		327
	68 [18]			108 [952] 419	199 [1764] 417	283 [2501] 416	362 [3201] 407	419 [3708] 401			374
	76 [20]			105 [929] 466	195 [1726] 465	280 [2476] 462	349 [3092] 453	453 [4008] 443			420

Overall Efficiency - 70 - 100%  40 - 69%  0 - 39%

Theoretical Torque - Nm [lb-in]

45 [394]	89 [788]	178 [1576]	267 [2365]	356 [3153]	445 [3941]	534 [4729]	623 [5518]
----------	----------	------------	------------	------------	------------	------------	------------

Displacement tested at 54°C [129°F] with an oil viscosity of 46cSt [213 SUS]



**200**

Pressure - bars [psi]							Max. Cont.	Max. Inter.
17 [250]	35 [500]	69 [1000]	104 [1500]	138 [2000]	173 [2500]	207 [3000]	241 [3500]	

204 cc [12.4 in<sup>3</sup>/rev.]

Intermittent Ratings - 10% of Operation

Flow - lpm [gpm]	Torque - Nm [lb-in], Speed rpm								Theoretical rpm
	40 [358] 7	91 [808] 4	133 [1181] 4	294 [2602] 4	375 [3323] 3				
2 [0.5]									10
4 [1]	43 [376] 16	85 [753] 13	200 [1769] 12	276 [2442] 11	373 [3304] 10	442 [3915] 9	526 [4656] 6		19
8 [2]	44 [385] 34	93 [851] 31	195 [1727] 29	299 [2646] 27	374 [3311] 27	461 [4079] 25	542 [4792] 23	616 [5451] 20	38
15 [4]	39 [347] 72	94 [834] 69	198 [1752] 67	305 [2701] 63	401 [3549] 60	477 [4222] 58	544 [4818] 55	629 [5568] 51	75
23 [6]		82 [724] 111	191 [1694] 109	284 [2518] 107	389 [3446] 103	463 [4098] 100	553 [4894] 99	636 [5628] 90	112
30 [8]		80 [704] 148	188 [1661] 145	285 [2518] 141	402 [3556] 136	458 [4053] 134	543 [4802] 130	628 [5554] 124	150
38 [10]		66 [581] 185	180 [1592] 181	276 [2445] 176	364 [3224] 173	458 [4051] 170	535 [4737] 164	615 [5441] 160	187
45 [12]			165 [1462] 221	261 [2312] 214	362 [3200] 210	450 [3982] 207	535 [4731] 198	618 [5471] 196	224
53 [14]			150 [1328] 257	273 [2413] 256	368 [3253] 247	449 [3975] 244	558 [4936] 241	602 [5328] 235	261
61 [16]			134 [1183] 296	253 [2242] 292	335 [2969] 284	435 [3850] 277	524 [4639] 273	598 [5292] 269	299
68 [18]			121 [1068] 334	232 [2056] 330	339 [3003] 327	416 [3686] 320	512 [4532] 313	599 [5299] 308	336
76 [20]			110 [970] 372	206 [1823] 372	308 [2725] 365	401 [3552] 357	507 [4484] 352		373
83 [22]				191 [1689] 407	285 [2520] 403	379 [3353] 397	486 [4303] 388		410

Overall Efficiency - 70 - 100%  40 - 69%  0 - 39%

Theoretical Torque - Nm [lb-in]

56 [494]	112 [987]	223 [1975]	335 [2962]	446 [3949]	558 [4936]	669 [5924]	781 [6911]
----------	-----------	------------	------------	------------	------------	------------	------------

Displacement tested at 54°C [129°F] with an oil viscosity of 46cSt [213 SUS]

**230**

Pressure - bars [psi]							Max. Cont.	Max. Inter.
17 [250]	35 [500]	69 [1000]	104 [1500]	138 [2000]	173 [2500]	207 [3000]	241 [3500]	

232 cc [14.2 in<sup>3</sup>/rev.]

Intermittent Ratings - 10% of Operation

Flow - lpm [gpm]	Torque - Nm [lb-in], Speed rpm								Theoretical rpm
	45 [397] 6	92 [813] 4	184 [1628] 3	293 [2590] 2	375 [3323] 1				
2 [0.5]									9
4 [1]	48 [429] 14	101 [890] 12	223 [1972] 11	316 [2793] 11	414 [3660] 9	493 [4366] 7	560 [4955] 4		17
8 [2]	51 [453] 30	105 [926] 27	215 [1899] 25	329 [2911] 25	425 [3760] 23	524 [4637] 20	618 [5468] 17	710 [6286] 12	33
15 [4]	43 [384] 63	108 [960] 59	209 [1851] 55	326 [2884] 54	435 [3846] 52	539 [4771] 47	655 [5799] 42	721 [6381] 39	66
23 [6]		102 [603] 93	213 [1889] 88	339 [3001] 85	428 [3789] 82	536 [4747] 77	628 [5559] 73	718 [6355] 69	98
30 [8]		89 [789] 127	207 [1830] 122	316 [2793] 120	425 [3762] 115	521 [4612] 110	639 [5653] 107	717 [6341] 98	131
38 [10]		78 [690] 161	198 [1750] 157	311 [2752] 151	436 [3856] 148	527 [4660] 143	612 [5420] 140	703 [6218] 132	163
45 [12]			189 [1669] 191	296 [2624] 186	425 [3764] 182	510 [4517] 176	599 [5304] 170	689 [6098] 163	196
53 [14]			177 [1565] 224	293 [2596] 216	388 [3434] 214	495 [4384] 208	587 [5197] 205	680 [6017] 198	228
61 [16]			150 [1326] 256	272 [2408] 255	397 [3509] 249	484 [4280] 245	574 [5077] 237	669 [5925] 227	261
68 [18]			142 [1261] 292	264 [2333] 286	355 [3140] 282	493 [4366] 276	569 [5032] 274	655 [5799] 259	293
76 [20]			122 [1083] 324	237 [2096] 321	347 [3068] 316	453 [4009] 309	571 [5057] 305		326
83 [22]				210 [1855] 357	338 [2987] 351	464 [4104] 345	550 [4864] 339		358

Overall Efficiency - 70 - 100%  40 - 69%  0 - 39%

Theoretical Torque - Nm [lb-in]

64 [565]	128 [1131]	256 [2261]	383 [3392]	511 [4522]	639 [5653]	767 [6783]	894 [7914]
----------	------------	------------	------------	------------	------------	------------	------------

Displacement tested at 54°C [129°F] with an oil viscosity of 46cSt [213 SUS]



**260**

Pressure - bars [psi]							Max. Cont.	Max. Inter.
17 [250]	35 [500]	69 [1000]	104 [1500]	138 [2000]	173 [2500]	207 [3000]	241 [3500]	

261 cc [15.9 in<sup>3</sup>/rev.]

Torque - Nm [lb-in], Speed rpm Intermittent Ratings - 10% of Operation

Flow - lpm [gpm]	2 [0.5]	49 [432] 5	112 [989] 2							Theoretical rpm
	4 [1]	54 [475] 12	113 [998] 11	240 [2125] 10	365 [3230] 9	478 [4227] 8	578 [5112] 7	648 [5736] 5		
	8 [2]	54 [474] 27	115 [1021] 25	247 [2184] 24	367 [3244] 22	488 [4318] 21	591 [5230] 19	703 [6223] 16		
	15 [4]	49 [429] 57	114 [1010] 55	261 [2307] 51	363 [3214] 51	486 [4300] 48	595 [5268] 46	697 [6171] 43	807 [7143] 39	
	23 [6]	45 [397] 86	115 [1016] 83	236 [2090] 80	364 [3221] 78	497 [4398] 76	590 [5225] 71	721 [6379] 68	802 [7096] 63	
	30 [8]		94 [833] 114	227 [2008] 109	348 [3078] 109	477 [4224] 105	592 [5239] 101	692 [6128] 96	794 [7027] 88	
	38 [10]		85 [752] 145	231 [2044] 144	340 [3013] 141	470 [4155] 138	585 [5180] 133	685 [6063] 127	796 [7048] 119	
	45 [12]		78 [692] 173	217 [1919] 173	354 [3135] 168	464 [4108] 166	567 [5018] 161	672 [5945] 153	802 [7095] 144	
	53 [14]		64 [563] 202	198 [1754] 202	326 [2886] 200	445 [3941] 196	568 [5026] 184	668 [5908] 181	765 [6771] 176	
	61 [16]			182 [1608] 231	299 [2644] 229	448 [3965] 221	552 [4884] 219	651 [5763] 216	752 [6659] 209	
	68 [18]			160 [1417] 261	304 [2693] 261	417 [3690] 256	550 [4870] 247	643 [5689] 240	740 [6551] 232	
	76 [20]			136 [1204] 290	278 [2460] 289	391 [3464] 285	521 [4614] 277	636 [5628] 274	736 [6516] 263	
	83 [22]			132 [1168] 319	263 [2325] 319	374 [3314] 315	512 [4535] 311	615 [5442] 301		
	91 [24]			82 [722] 348	227 [2009] 347	361 [3190] 345	496 [4386] 340			

Overall Efficiency - 70 - 100%  40 - 69%  0 - 39%

Theoretical Torque - Nm [lb-in]

72 [633]	143 [1266]	286 [2532]	429 [3798]	572 [5064]	715 [6330]	858 [7596]	1001 [8861]
----------	------------	------------	------------	------------	------------	------------	-------------

Displacement tested at 54°C [129°F] with an oil viscosity of 46cSt [213 SUS]

**300**

Pressure - bars [psi]							Max. Cont.	Max. Inter.
17 [250]	35 [500]	69 [1000]	104 [1500]	138 [2000]	173 [2500]	207 [3000]	241 [3500]	

300 cc [18.3 in<sup>3</sup>/rev.]

Torque - Nm [lb-in], Speed rpm Intermittent Ratings - 10% of Operation

Flow - lpm [gpm]	2 [0.5]	51 [452] 3	95 [839] 1							Theoretical rpm
	4 [1]	63 [557] 11	145 [1282] 10	302 [2675] 9	433 [3829] 8	510 [4513] 7	627 [5552] 4			
	8 [2]	62 [551] 22	158 [1400] 20	308 [2722] 19	437 [3866] 19	571 [5056] 16	679 [6011] 13	768 [6796] 9	830 [7346] 5	
	15 [4]	66 [588] 48	145 [1281] 47	316 [2793] 45	430 [3805] 43	577 [5107] 38	680 [6015] 33	820 [7258] 28	908 [8040] 21	
	23 [6]	58 [511] 75	140 [1241] 75	290 [2566] 72	424 [3755] 69	546 [4830] 65	690 [6105] 57	801 [7088] 49	946 [8372] 40	
	30 [8]	46 [405] 100	128 [1136] 100	305 [2699] 99	391 [3460] 96	571 [5056] 87	700 [6199] 82	826 [7313] 71	930 [8233] 62	
	38 [10]		111 [981] 125	282 [2493] 124	409 [3623] 121	503 [4447] 115	683 [6043] 106	794 [7028] 98	919 [8131] 88	
	45 [12]		92 [814] 150	261 [2313] 150	388 [3435] 148	472 [4177] 143	641 [5676] 133	783 [6927] 122	881 [7794] 113	
	53 [14]		77 [684] 176	245 [2165] 175	391 [3464] 175	530 [4687] 173	661 [5848] 163	809 [7157] 151	949 [8398] 138	
	61 [16]		63 [553] 201	224 [1983] 201	366 [3243] 199	508 [4498] 192	633 [5599] 187	796 [7044] 173	916 [8103] 163	
	68 [18]			201 [1780] 225	339 [2999] 225	467 [4135] 222	666 [5898] 211	804 [7115] 199	899 [7955] 194	
	76 [20]			172 [1522] 251	327 [2895] 251	480 [4247] 247	611 [5410] 240	745 [6596] 232	910 [8051] 217	
	83 [22]			144 [1276] 277	321 [2836] 276	466 [4127] 269	575 [5084] 263	732 [6474] 254		
	91 [24]			119 [1049] 302	281 [2483] 301	435 [3853] 300	559 [4943] 291	703 [6223] 280		
95 [25]			105 [928] 315	262 [2319] 314	434 [3838] 311	553 [4894] 307	707 [6257] 294			

Overall Efficiency - 70 - 100%  40 - 69%  0 - 39%

Theoretical Torque - Nm [lb-in]

82 [729]	165 [1457]	329 [2914]	494 [4371]	659 [5828]	823 [7285]	988 [8742]	1152 [10199]
----------	------------	------------	------------	------------	------------	------------	--------------

Displacement tested at 54°C [129°F] with an oil viscosity of 46cSt [213 SUS]



**350**

Pressure - bars [psi]							Max. Cont.	Max. Inter.
17 [250]	35 [500]	69 [1000]	104 [1500]	138 [2000]	173 [2500]	207 [3000]	241 [3500]	

348 cc [21.2 in<sup>3</sup>/rev.]

Flow - lpm [gpm]	2 [0.5]
	4 [1]
	8 [2]
	15 [4]
	23 [6]
	30 [8]
	38 [10]
	45 [12]
	53 [14]
	61 [16]
Max. Cont.	68 [18]
	76 [20]
	83 [22]
	91 [24]
Max. Inter.	95 [25]

Torque - Nm [lb-in], Speed rpm	Intermittent Ratings - 10% of Operation						
64 [566] 4	134 [1183] 4	272 [2404] 3	399 [3532] 2				
64 [570] 10	134 [1189] 9	296 [2619] 8	437 [3869] 8				
69 [607] 21	145 [1285] 20	312 [2764] 19	462 [4092] 18	600 [5308] 18	742 [6571] 17	855 [7569] 14	
71 [627] 42	151 [1340] 41	313 [2767] 40	471 [4169] 39	630 [5577] 37	772 [6834] 35	889 [7869] 34	993 [8785] 28
62 [549] 64	149 [1618] 63	315 [2788] 62	474 [4191] 60	630 [5577] 57	768 [6796] 54	925 [8182] 51	1032 [9137] 45
53 [472] 86	139 [1233] 85	307 [2713] 84	459 [4058] 82	626 [5537] 79	768 [6793] 75	928 [8210] 69	1051 [9300] 65
	113 [1004] 108	298 [2639] 108	431 [3814] 108	601 [5317] 102	745 [6593] 100	910 [8056] 93	1062 [9399] 87
	98 [869] 130	265 [2346] 129	445 [3936] 128	581 [5144] 125	740 [6552] 117	891 [7889] 109	1044 [9237] 104
	86 [758] 152	252 [2226] 151	422 [3738] 150	570 [5044] 147	723 [6398] 139	881 [7794] 133	1031 [9126] 120
	63 [560] 173	235 [2079] 173	409 [3619] 172	549 [4859] 170	720 [6375] 163	850 [7522] 155	1012 [8952] 147
		220 [1948] 195	394 [3490] 194	571 [5054] 190	693 [6134] 187	839 [7428] 175	986 [8727] 164
		208 [1843] 217	375 [3320] 216	513 [4544] 214	683 [6044] 213	835 [7385] 195	975 [8632] 188
		179 [1583] 239	352 [3112] 239	554 [4906] 238	685 [6064] 233	813 [7198] 221	958 [8482] 215
		172 [1526] 261	360 [3186] 261	534 [4724] 260	666 [5890] 256		
			369 [3264] 271	529 [4682] 270	647 [5730] 265		

Theoretical rpm	6
	11
	22
	44
	66
	88
	109
	131
	153
	175
Max. Cont.	197
	218
	240
	262
Max. Inter.	273

Overall Efficiency - 70 - 100%  40 - 69%  0 - 39%

Theoretical Torque - Nm [lb-in]

95 [844]	191 [1688]	381 [3376]	572 [5064]	763 [6752]	954 [8439]	1144 [10127]	1335 [11815]
----------	------------	------------	------------	------------	------------	--------------	--------------

Displacement tested at 54°C [129°F] with an oil viscosity of 46cSt [213 SUS]

**375**

Pressure - bars [psi]							Max. Cont.	Max. Inter.
17 [250]	35 [500]	69 [1000]	104 [1500]	138 [2000]	173 [2500]	207 [3000]	241 [3500]	

375 cc [22.8 in<sup>3</sup>/rev.]

Flow - lpm [gpm]	2 [0.5]
	4 [1]
	8 [2]
	15 [4]
	23 [6]
	30 [8]
	38 [10]
	45 [12]
	53 [14]
	61 [16]
Max. Cont.	68 [18]
	76 [20]
	83 [22]
	91 [24]
Max. Inter.	95 [25]

Torque - Nm [lb-in], Speed rpm	Intermittent Ratings - 10% of Operation						
76 [674] 3							
84 [745] 8	162 [1432] 7	329 [2911] 6	490 [4337] 6	639 [5652] 5	763 [6756] 3		
82 [724] 18	171 [1510] 17	361 [3196] 16	537 [4754] 16	689 [6095] 14	836 [7399] 12	955 [8449] 9	
77 [680] 39	163 [1439] 37	358 [3164] 37	537 [4756] 36	695 [6151] 32	857 [7587] 29	989 [8750] 25	1121 [9923] 20
67 [595] 60	158 [1398] 59	354 [3130] 56	527 [4661] 56	695 [6155] 52	864 [7642] 47	1011 [8951] 40	1168 [10334] 36
57 [508] 80	149 [1321] 80	340 [3010] 78	510 [4512] 77	695 [6154] 71	845 [7476] 65	1009 [8930] 60	1156 [10229] 51
	134 [1187] 100	322 [2849] 99	495 [4383] 96	681 [6024] 93	836 [7399] 87	1007 [8913] 80	1157 [10235] 71
	115 [1013] 121	301 [2661] 120	480 [4249] 118	645 [5711] 113	809 [7159] 108	980 [8674] 98	1141 [10098] 92
	93 [819] 141	280 [2475] 140	477 [4218] 138	633 [5602] 134	795 [7036] 128	949 [8402] 120	1117 [9887] 105
	73 [646] 161	261 [2314] 161	429 [3797] 160	598 [5296] 155	770 [6817] 151	934 [8267] 141	1085 [9605] 130
		236 [2091] 181	434 [3843] 181	597 [5282] 177	765 [6771] 168	907 [8026] 161	1080 [9554] 150
		209 [1851] 202	384 [3396] 201	561 [4969] 198	740 [6549] 191	877 [7764] 183	1027 [9091] 168
		178 [1576] 222	374 [3309] 221	530 [4694] 218	696 [6160] 213	840 [7431] 205	
		141 [1246] 242	319 [2822] 241	511 [4523] 239	662 [5860] 233		

Theoretical rpm	6
	11
	21
	41
	61
	82
	102
	122
	142
	163
Max. Cont.	183
	203
	223
	244

Overall Efficiency - 70 - 100%  40 - 69%  0 - 39%

Theoretical Torque - Nm [lb-in]

103 [908]	205 [1815]	410 [3631]	615 [5446]	821 [7261]	1026 [9076]	1231 [10892]	1436 [12707]
-----------	------------	------------	------------	------------	-------------	--------------	--------------

Displacement tested at 54°C [129°F] with an oil viscosity of 46cSt [213 SUS]



**470**

Pressure - bars [psi]				Max. Cont.	Peak
17 [250]	35 [500]	69 [1000]	104 [1500]	138 [2000]	173 [2500] 207 [3000]

465 cc [28.3 in<sup>3</sup>/rev.]

Torque - Nm [lb-in], Speed rpm Intermittent Ratings - 10% of Operation

Flow - lpm [gpm]	2 [0.5]	93 [823] 2	185 [1635] 1							5	Theoretical rpm
	4 [1]	97 [857] 7	203 [1794] 5	409 [3618] 5	610 [5402] 5	815 [7209] 4				9	
	8 [2]	98 [865] 15	209 [1845] 14	435 [3851] 13	659 [5836] 13	855 [7563] 12	1025 [9071] 11	1196 [10586] 9		17	
	15 [4]	94 [834] 31	200 [1774] 30	444 [3932] 28	659 [5829] 28	886 [7836] 26	1066 [9434] 23	1250 [11062] 21		33	
	23 [6]	86 [759] 48	193 [1704] 47	438 [3880] 44	673 [5955] 44	872 [7715] 41	1073 [9499] 37	1258 [11128] 32		49	
	30 [8]	73 [643] 64	179 [1587] 63	424 [3752] 60	663 [5863] 60	857 [7586] 57	1098 [9718] 50	1279 [11317] 43		66	
	38 [10]	52 [464] 81	164 [1455] 80	407 [3597] 78	627 [5550] 78	851 [7533] 75	1067 [9444] 68	1276 [11288] 61		82	
	45 [12]		141 [1248] 97	379 [3350] 94	630 [5575] 93	832 [7363] 90	1067 [9441] 83	1273 [11264] 76		98	
	53 [14]		114 [1006] 113	350 [3094] 112	580 [5133] 111	802 [7101] 108	1013 [8964] 102	1222 [10817] 94		115	
	61 [16]		83 [736] 130	322 [2846] 129	545 [4819] 127	796 [7040] 123	965 [8538] 119	1190 [10528] 113		131	
	68 [18]		56 [497] 146	275 [2434] 145	526 [4657] 145	737 [6519] 142	956 [8464] 138	1166 [10317] 128		147	
	76 [20]			235 [2078] 162	479 [4239] 161	706 [6249] 158	917 [8117] 154	1122 [9933] 143		164	
	83 [22]			202 [1790] 179	460 [4075] 178	669 [5920] 176	883 [7811] 170			180	
	91 [24]			157 [1392] 195	385 [3410] 194	620 [5484] 190	843 [7464] 186			196	

Overall Efficiency - 70 - 100%  40 - 69%  0 - 39%

Theoretical Torque - Nm [lb-in]

127 [1127]	255 [2253]	509 [4506]	764 [6760]	1018 [9013]	1273 [11266]	1528 [13519]
------------	------------	------------	------------	-------------	--------------	--------------

Displacement tested at 54°C [129°F] with an oil viscosity of 46cSt [213 SUS]

**540**

Pressure - bars [psi]				Max. Cont.	Max. Inter.
17 [250]	35 [500]	69 [1000]	104 [1500]	138 [2000]	173 [2500]

536 cc [32.7 in<sup>3</sup>/rev.]

Torque - Nm [lb-in], Speed rpm Intermittent Ratings - 10% of Operation

Flow - lpm [gpm]	2 [0.5]	104 [921] 2	197 [1748] 2							4	Theoretical rpm
	4 [1]	126 [1111] 6	230 [2031] 5	467 [4136] 5	699 [6183] 5	939 [8310] 5	1149 [10165] 4			8	
	8 [2]	134 [1189] 13	240 [2120] 13	501 [4436] 12	755 [6679] 12	977 [8646] 11	1185 [10484] 10			15	
	15 [4]	120 [1058] 27	232 [2055] 27	510 [4510] 26	757 [6697] 26	988 [8740] 24	1223 [10827] 23			29	
	23 [6]	97 [859] 41	224 [1984] 41	505 [4469] 40	783 [6930] 40	993 [8787] 38	1225 [10838] 34			43	
	30 [8]	78 [692] 56	213 [1887] 56	484 [4285] 55	750 [6635] 54	983 [8698] 53	1251 [11075] 48			57	
	38 [10]	59 [523] 70	190 [1678] 70	455 [4026] 69	728 [6445] 69	959 [8487] 67	1244 [11008] 62			71	
	45 [12]		176 [1554] 84	438 [3879] 83	719 [6360] 83	945 [8360] 80	1203 [10646] 77			85	
	53 [14]		139 [1233] 98	418 [3703] 97	682 [6035] 96	952 [8421] 94	1183 [10467] 91			99	
	61 [16]		109 [963] 112	385 [3407] 111	668 [5908] 110	899 [7957] 110	1163 [10290] 105			114	
	68 [18]		83 [736] 126	356 [3154] 126	612 [5417] 125	869 [7694] 124	1116 [9876] 123			128	
	76 [20]			323 [2861] 140	603 [5333] 139	829 [7335] 138	1109 [9816] 134			142	
	83 [22]			297 [2629] 154	537 [4753] 153	792 [7011] 152				156	
	91 [24]			215 [1905] 169	491 [4349] 168	750 [6639] 168				170	

Overall Efficiency - 70 - 100%  40 - 69%  0 - 39%

Theoretical Torque - Nm [lb-in]

147 [1302]	294 [2604]	588 [5207]	883 [7811]	1177 [10414]	1471 [13018]
------------	------------	------------	------------	--------------	--------------

Displacement tested at 54°C [129°F] with an oil viscosity of 46cSt [213 SUS]

# RE

## PERFORMANCE



**750**

Pressure - bars [psi]		Max. Cont.	Peak
17 [250]	35 [500]	69 [1000]	104 [1500]
			138 [2000]

748 cc [45.6 in<sup>3</sup>/rev.]

Torque - Nm [lb-in], **Speed rpm** **Intermittent Ratings - 10% of Operation**

Flow - lpm [gpm]	Torque - Nm [lb-in]					Theoretical rpm
2 [0.5]	147 [1299] 2	281 [2487] 1				3
4 [1]	156 [1379] 4	322 [2852] 4	652 [5768] 4	967 [8554] 3	1308 [11571] 3	6
8 [2]	158 [1403] 9	339 [3003] 9	693 [6134] 9	1027 [9088] 8	1360 [12033] 7	11
15 [4]	153 [1350] 19	331 [2933] 19	705 [6241] 19	1064 [9419] 18	1416 [12534] 16	21
23 [6]	135 [1194] 29	321 [2840] 29	697 [6166] 28	1059 [9373] 28	1408 [12462] 26	31
30 [8]	114 [1008] 40	304 [2690] 40	678 [6002] 39	1039 [9197] 38	1421 [12573] 34	41
38 [10]	82 [722] 50	271 [2395] 49	648 [5733] 49	1015 [8980] 48	1371 [12130] 47	51
45 [12]	54 [477] 60	249 [2207] 60	616 [5452] 59	983 [8699] 59	1345 [11902] 56	61
53 [14]		197 [1739] 70	577 [5104] 69	946 [8372] 68	1311 [11600] 67	71
61 [16]		150 [1325] 80	533 [4718] 79	905 [8008] 78	1271 [11249] 76	82
68 [18]		105 [927] 90	494 [4374] 90	860 [7614] 89	1225 [10843] 88	92
76 [20]		62 [552] 100	423 [3741] 100	805 [7123] 99	1173 [10385] 98	102
83 [22]			385 [3404] 110	747 [6608] 110		112
91 [24]			302 [2669] 121	670 [5932] 120		122

Overall Efficiency - 70 - 100%  40 - 69%  0 - 39%

Theoretical Torque - Nm [lb-in]

205 [1815]	410 [3631]	821 [7261]	1231 [10892]	1641 [14522]
------------	------------	------------	--------------	--------------

Displacement tested at 54°C [129°F] with an oil viscosity of 46cSt [213 SUS]



NOTE: Dimensions shown are without paint. Paint thickness can be up to 0,13 [.005]

500 & 501 SERIES HOUSINGS (SAE A MOUNT)

**A31** 4-Hole 7/8" O-Ring Aligned Ports

**A38** 4-Hole 1/2" BSP.F Aligned Ports

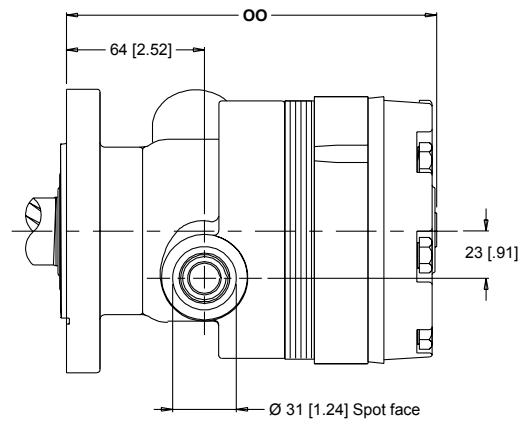
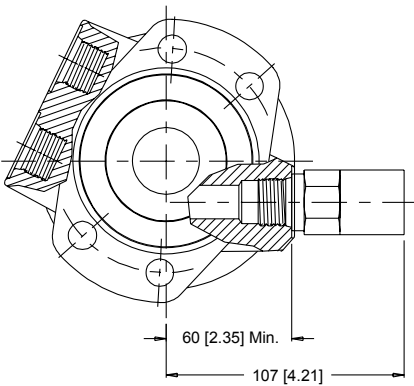
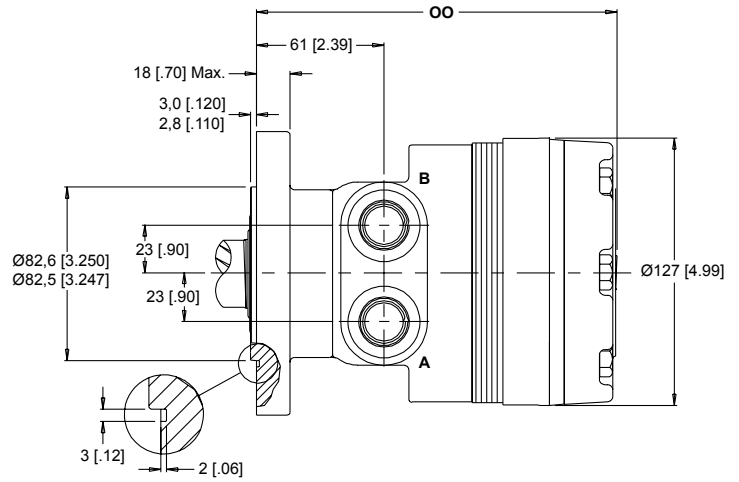
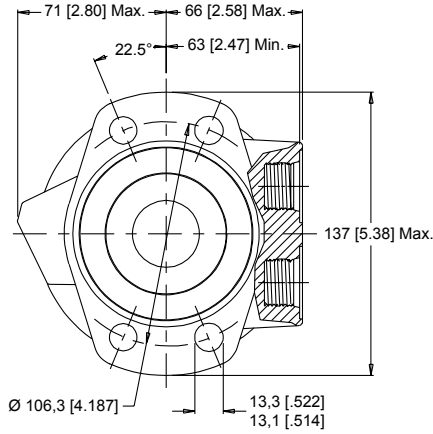

NOTE: Dimension OO is found on page 11. Optional Relief Cartridge shown installed and is available for both the A31 and A38 housings. Valve Cavity - 10 Series/2-way (7/8"-14 UNF-2B)

**A51** 6-Hole 7/8" O-Ring Aligned Ports

**A58** 6-Hole 1/2" BSP.F Aligned Ports

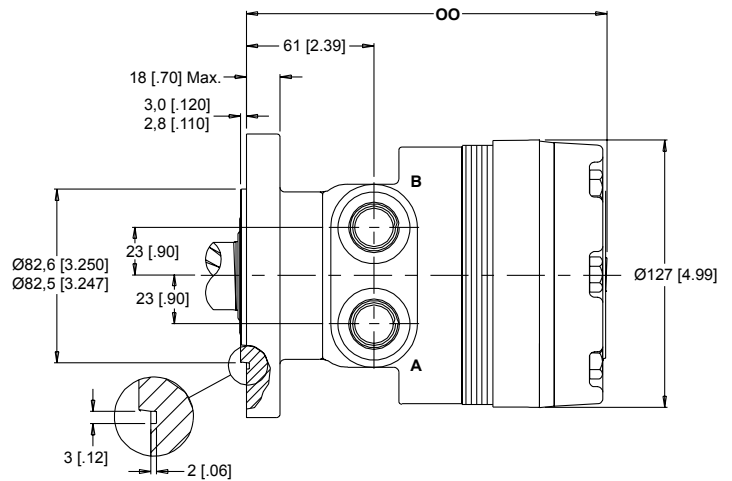
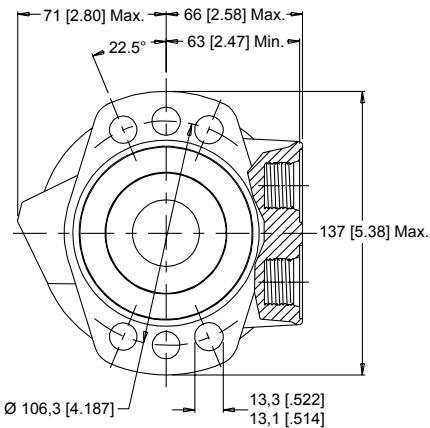



NOTE: Dimensions shown are without paint. Paint thickness can be up to 0,13 [.005]

## 500 & 501 SERIES HOUSINGS (WHEEL MOUNT)

**W31** 4-Hole 7/8" O-Ring Aligned Ports

**W38** 4-Hole 1/2" BSP.F Aligned Ports

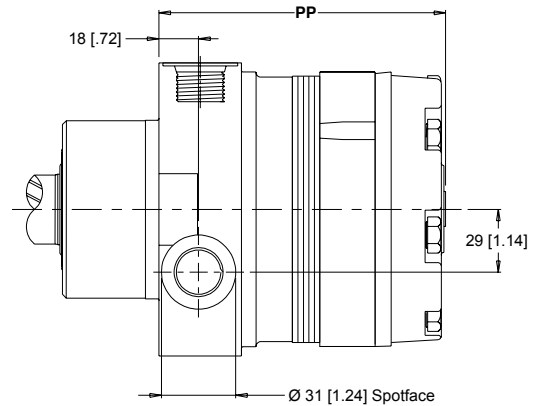
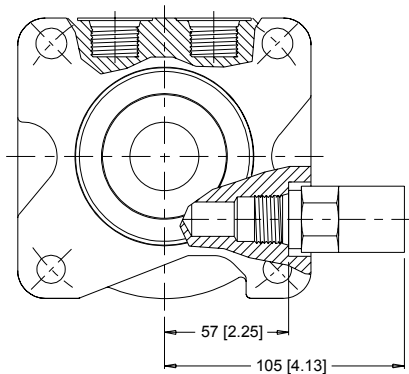
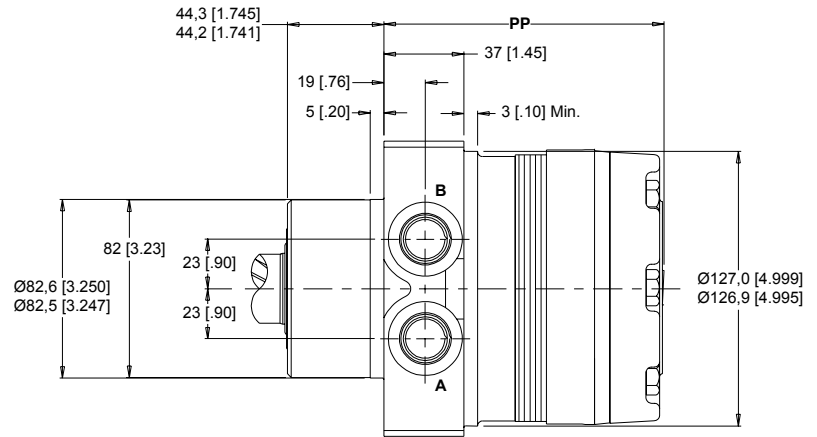
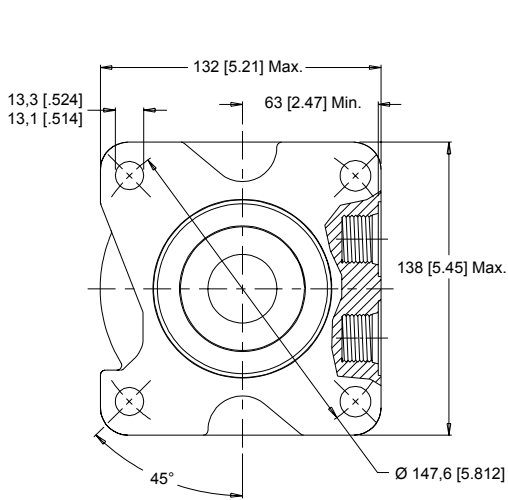

**NOTE:** Dimension PP is found on page 11. Optional Relief Cartridge shown installed and is available for both the W31 and W38 housings. Valve Cavity - 10 Series/2-way (7/8"-14 UNF-2B)



## 500 & 501 SERIES TECHNICAL INFORMATION

**Bearing Curve:** The bearing curve represents allowable bearing loads based on ISO 281 bearing capacity for an  $L_{10}$  life of 2,000 hours at 100 rpm. Radial loads for speeds other than 100 rpm may be calculated using the multiplication factor table located below.

### SAE A FLANGE

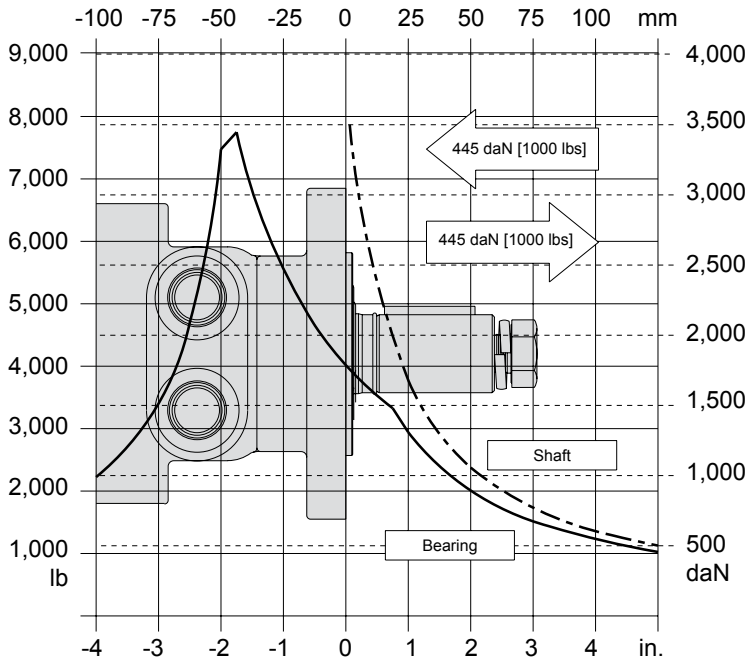

### WHEEL MOUNT

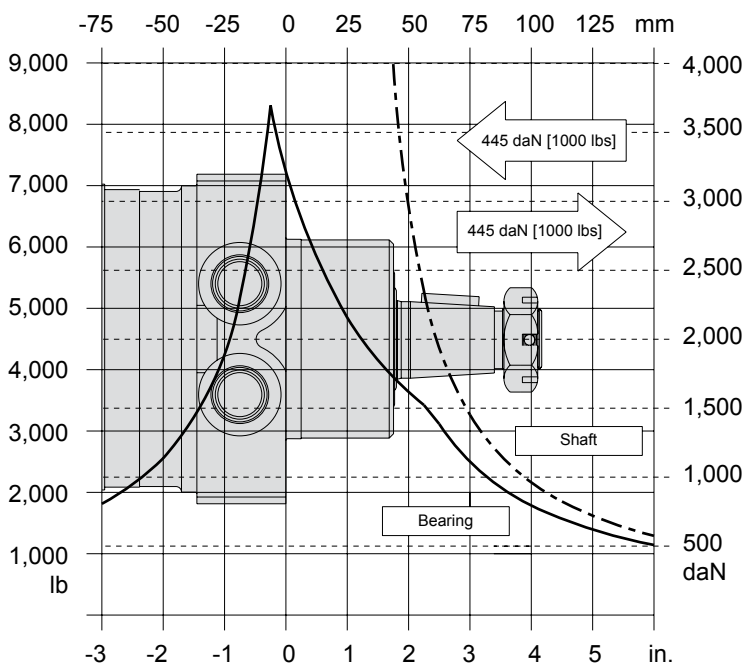

LENGTH / WEIGHT CHART SAE A Mount - Dimension OO		
Code	mm [in]	kg [lb]
120	162 [6.37]	10,6 [23.4]
160	162 [6.37]	10,6 [23.4]
200	165 [6.51]	11,0 [24.2]
230	168 [6.61]	11,1 [24.4]
260	170 [6.70]	11,3 [25.0]
300	174 [6.83]	11,7 [25.8]
350	187 [7.38]	12,8 [28.2]
375	180 [7.08]	12,2 [27.0]
470	187 [7.38]	12,8 [28.2]
540	194 [7.62]	13,3 [29.4]
750	212 [8.33]	14,8 [32.5]

**NOTE:**  
RE motor weights vary  $\pm 0,5$  kg [1 lb] depending upon motor configuration.

LENGTH / WEIGHT CHART Wheel Mount - Dimension PP		
Code	mm [in]	kg [lb]
120	120 [4.72]	11,7 [25.8]
160	120 [4.72]	11,7 [25.8]
200	123 [4.86]	12,1 [26.6]
230	126 [4.95]	12,2 [26.8]
260	128 [5.05]	12,4 [27.4]
300	132 [5.18]	12,8 [28.2]
350	146 [5.73]	13,9 [30.6]
375	138 [5.43]	13,3 [29.4]
470	146 [5.73]	13,9 [30.6]
540	152 [5.97]	14,4 [31.8]
750	170 [6.68]	15,8 [34.9]

**NOTE:**  
RE motor weights vary  $\pm 0,5$  kg [1 lb] depending upon motor configuration.

BEARING LOAD MULTIPLICATION FACTOR TABLE	
RPM	FACTOR
50	1.23
100	1.00
200	0.81
300	0.72
400	0.66
500	0.62
600	0.58
700	0.56
800	0.50



### 10 1" Straight

Max. Torque: 660 Nm [5880 lb-in]

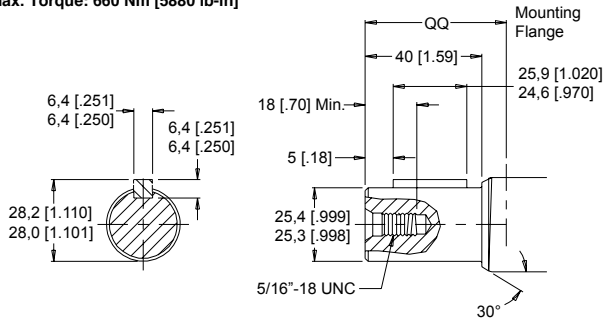

### 12 25mm Straight

Max. Torque: 635 Nm [5617 lb-in]

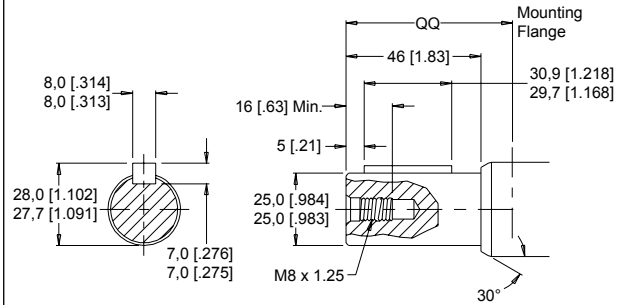

### 20 1-1/4" Straight

Max. Torque: 1200 Nm [10600 lb-in]

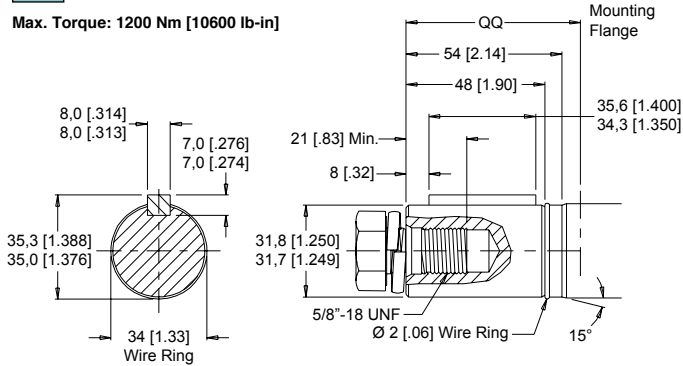

### 21 32mm Straight

Max. Torque: 1200 Nm [10600 lb-in]

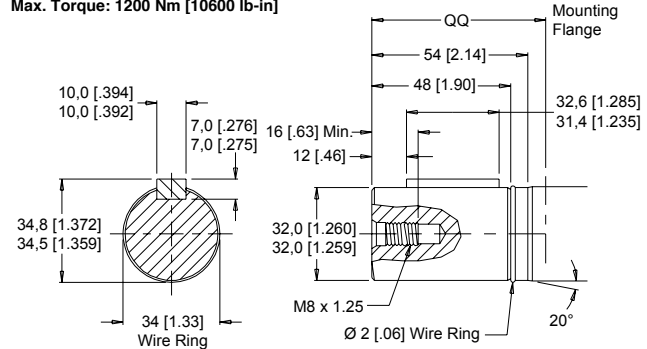

### 22 1-1/4" Tapered

Max. Torque: 1200 Nm [10600 lb-in]

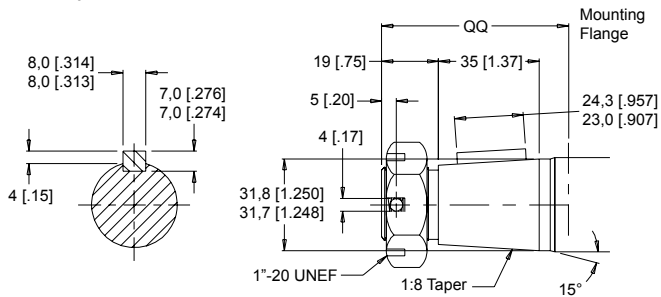

Note: A slotted nut is standard on this shaft.

### 02 6B Spline

Max. Torque: 429 Nm [3800 lb-in]

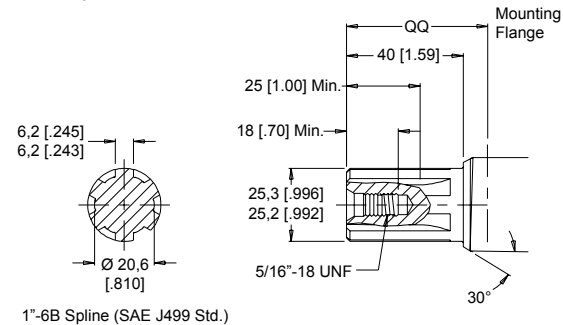

1"-6B Spline (SAE J499 Std.)

### 23 14 Tooth Spline

Max. Torque: 1200 Nm [10600 lb-in]

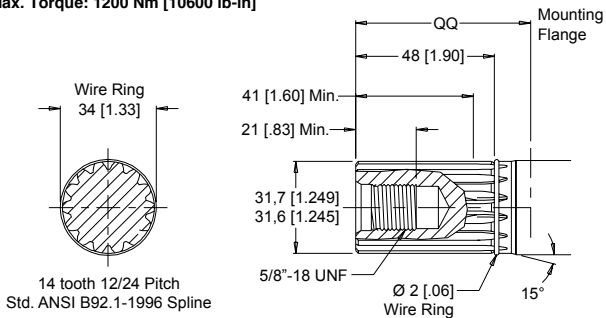

MOUNTING FLANGE TO SHAFT END Dimension QQ		
Code	SAE A Mount mm [in]	Wheel Mount mm [in]
02	50 [1.97]	91 [3.60]
10	50 [1.97]	91 [3.60]
12	56 [2.21]	98 [3.84]
20	61 [2.41]	103 [4.05]
21	61 [2.41]	103 [4.05]
22	66 [2.58]	107 [4.22]
23	61 [2.41]	103 [4.05]



## 500 & 501 SERIES MODEL CODE BUILDER

SERIES	DISPLACEMENT	HOUSING	SHAFT	PAINT	CAVITY	ADD ON	MISCELLANEOUS
STEP 1	STEP 2	STEP 3	STEP 4	STEP 5	STEP 6	STEP 7	STEP 8

### STEP 1 - Select a series

- 500 Counterclockwise Rotation
- 501 Clockwise Rotation

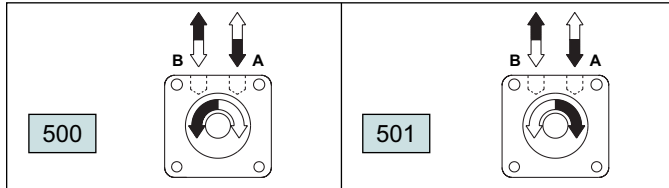

**NOTE:** For applications requiring the motor to rotate in only one direction, shaft seal life may be prolonged by pressurizing the "A" port of the motor. To obtain the desired direction of shaft rotation, use the graphic above to determine the rotation code for the motor. For bi-directional applications, the 500 series is recommended. Preferred rotation is determined by internal valving design.

### STEP 2 - Select a displacement option

120	121 cc [7.4 in <sup>3</sup> /rev]	350	348 cc [21.2 in <sup>3</sup> /rev]
160	162 cc [9.9 in <sup>3</sup> /rev]	375	375 cc [22.8 in <sup>3</sup> /rev]
200	204 cc [12.4 in <sup>3</sup> /rev]	470	465 cc [28.3 in <sup>3</sup> /rev]
230	232 cc [14.2 in <sup>3</sup> /rev]	540	536 cc [32.7 in <sup>3</sup> /rev]
260	261 cc [15.9 in <sup>3</sup> /rev]	750	748 cc [45.6 in <sup>3</sup> /rev]
300	300 cc [18.3 in <sup>3</sup> /rev]		

### STEP 3 - Select a housing option

- A31 4-Hole 7/8" O-Ring Aligned Ports (S)
- A38 4-Hole 1/2" BSP.F Aligned Ports (S)
- A51 6-Hole 7/8" O-Ring Aligned Ports (S)
- A58 6-Hole 1/2" BSP.F Aligned Ports (S)
- W31 4-Hole 7/8" O-Ring Aligned Ports
- W38 4-Hole 1/2" BSP.F Aligned Ports

### STEP 4 - Select a shaft option

02	6B Spline	03	6B Spline Extended (S)
10	1" Straight	15	1" Straight Extended (S)
12	25mm Straight	07	1-1/4" Straight Extended (S)
20	1-1/4" Straight	08	32mm Straight Extended (S)
21	32mm Straight	25	1-1/4" Tapered Extended (S)
22	1-1/4" Tapered	09	14 Tooth Spline Extended (S)
23	14 Tooth Spline		

**NOTE:** Extended shafts are intended for use when ordering a speed sensor motor. Dimensional data for these shafts are found in the RE (520) series section of this catalog.

### STEP 5 - Select a paint option

- A Black
- B Black (unpainted flange face)
- Z No Paint

### STEP 6 - Select a valve cavity option

- A None
- B Relief Valve Cavity
- C 1000 psi Relief Valve Installed
- D 1250 psi Relief Valve Installed
- E 1500 psi Relief Valve Installed
- F 1750 psi Relief Valve Installed
- G 2000 psi Relief Valve Installed
- J 2500 psi Relief Valve Installed
- L 3000 psi Relief Valve Installed

### STEP 7 - Select an add on option

- A Standard
- B Lock Nut
- C Solid Hex Nut
- W 4-Pin Dual Male Weatherpack Connector (S)
- X 4-Pin M12 Dual Male Connector (S)
- Y 3-Pin Single Male Weatherpack Connector (S)
- Z 4-Pin M12 Single Male Connector (S)

**NOTE:** (S) - STEP 3 Housings available for use with speed sensors. STEP 4 Shafts available for use with speed sensors. STEP 7 Speed sensor options.

### STEP 8 - Select a miscellaneous option

- AA None
- AC Freeturning Rotor
- AE Hydraulic Declutch with Freeturning Rotor



NOTE: Dimensions shown are without paint. Paint thickness can be up to 0,13 [.005]

## 520 & 521 SERIES HOUSINGS (WHEEL & SAE A MOUNTS)

**W31** 4-Hole 7/8" O-Ring Aligned Ports

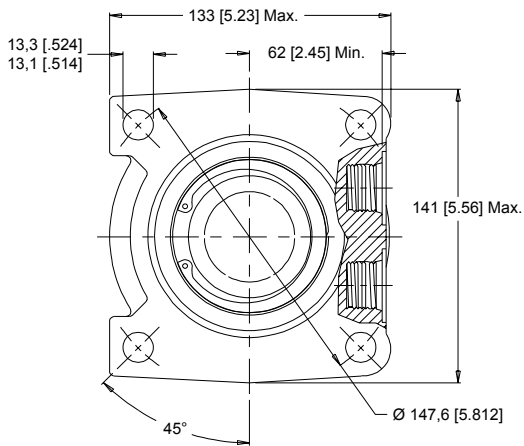

**W38** 4-Hole 1/2" BSP.F Aligned Ports

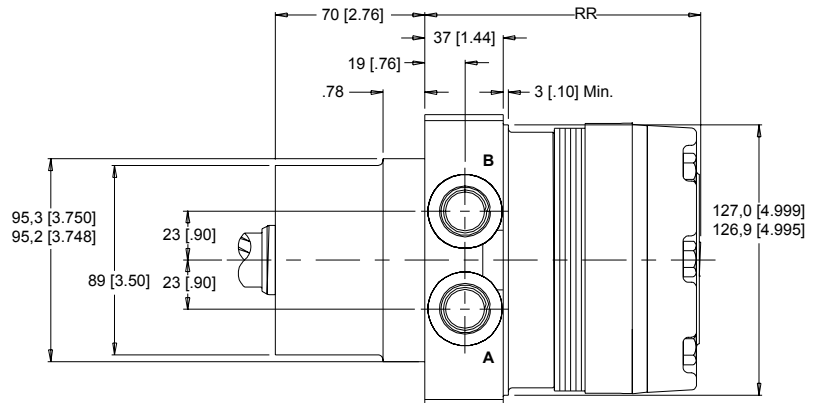

NOTE: Dimension RR is found on page 15.

**A51** 6-Hole 7/8" O-Ring Aligned Ports

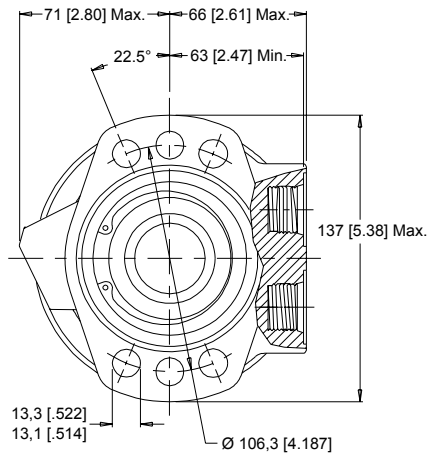

**A58** 6-Hole 1/2" BSP.F Aligned Ports

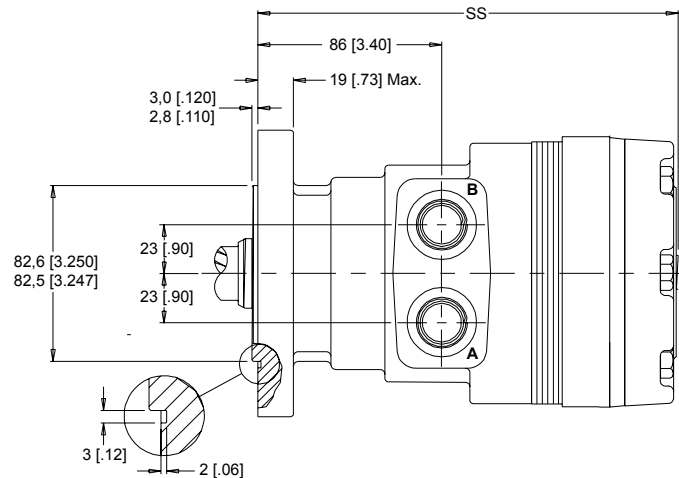

**A57** 6-Hole Manifold Aligned Ports

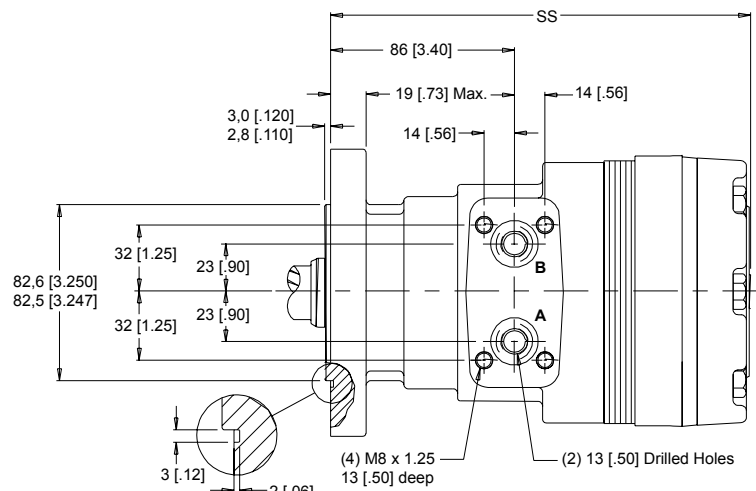
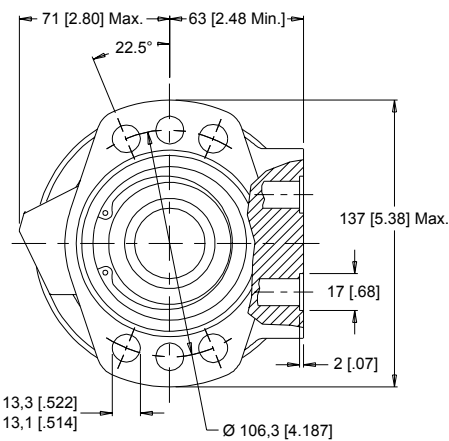

NOTE: Dimension SS is found on page 15.



## 520 & 521 SERIES TECHNICAL INFORMATION

**Bearing Curve:** The bearing curve represents allowable bearing loads based on ISO 281 bearing capacity for an  $L_{10}$  life of 2,000 hours at 100 rpm. Radial loads for speeds other than 100 rpm may be calculated using the multiplication factor table located on page 11.

### WHEEL MOUNT

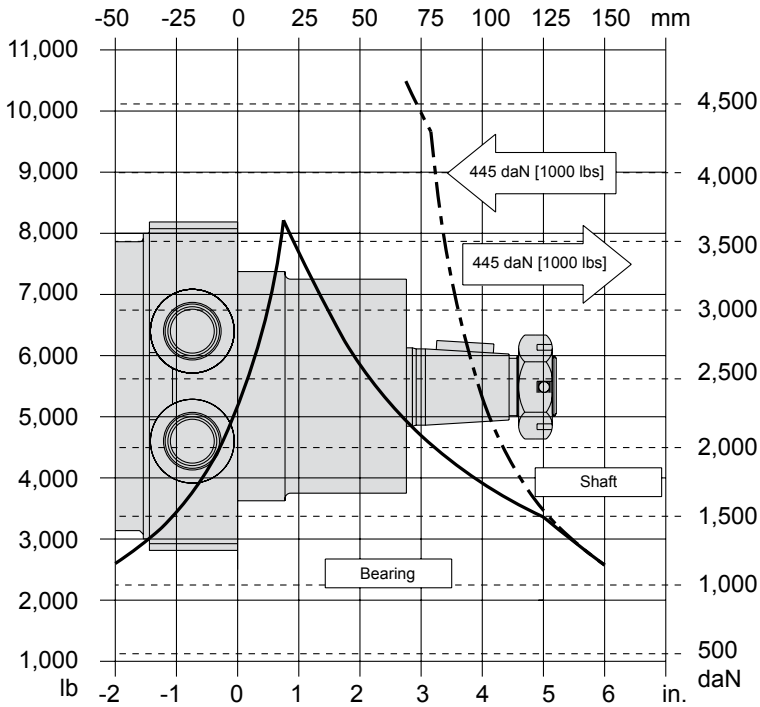

### SAE A FLANGE

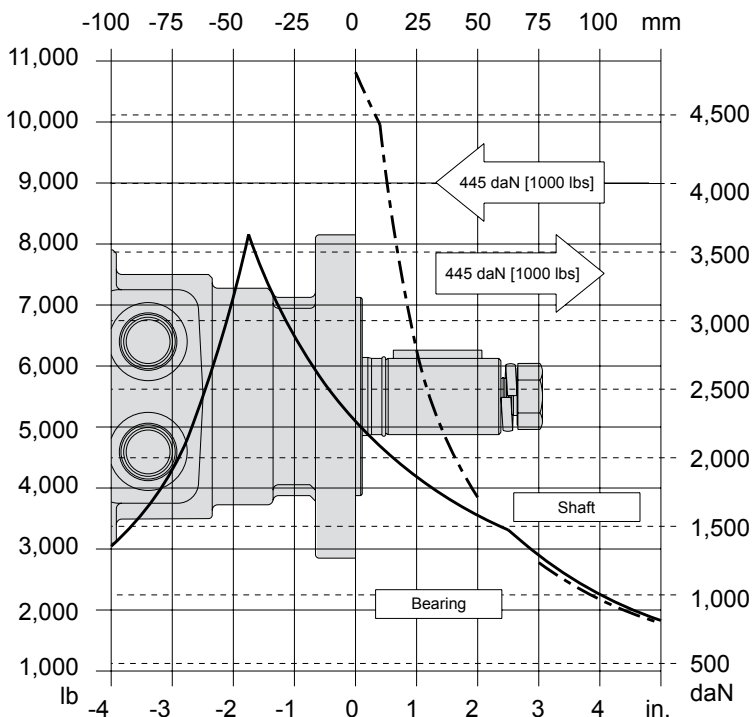

LENGTH / WEIGHT CHART Wheel Mount - Dimension RR		
Code	mm [in]	kg [lb]
120	120 [4.72]	12,9 [28.4]
160	120 [4.72]	12,9 [28.4]
200	123 [4.86]	13,2 [29.2]
230	126 [4.95]	13,3 [29.4]
260	128 [5.05]	13,6 [30.0]
300	132 [5.18]	14,0 [30.8]
350	146 [5.73]	15,1 [33.2]
375	138 [5.43]	14,5 [32.0]
470	146 [5.73]	15,1 [33.2]
540	152 [5.97]	15,6 [34.4]
750	170 [6.68]	17,0 [37.5]

**NOTE:**  
RE motor weights vary  $\pm 0,5$  kg [1 lb] depending upon motor configuration.

LENGTH / WEIGHT CHART SAE A Mount - Dimension SS		
Code	mm [in]	kg [lb]
120	187 [7.37]	13,3 [29.4]
160	187 [7.37]	13,3 [29.4]
200	191 [7.51]	13,7 [30.2]
230	193 [7.61]	13,8 [30.4]
260	196 [7.70]	14,1 [31.0]
300	199 [7.83]	14,4 [31.8]
350	213 [8.38]	15,5 [34.2]
375	205 [8.08]	15,0 [33.0]
470	213 [8.38]	15,5 [34.2]
540	219 [8.62]	16,1 [35.4]
750	237 [9.33]	17,5 [38.5]

**NOTE:**  
RE motor weights vary  $\pm 0,5$  kg [1 lb] depending upon motor configuration.



### 15 1" Straight

Max. Torque: 660 Nm [5880 lb-in]

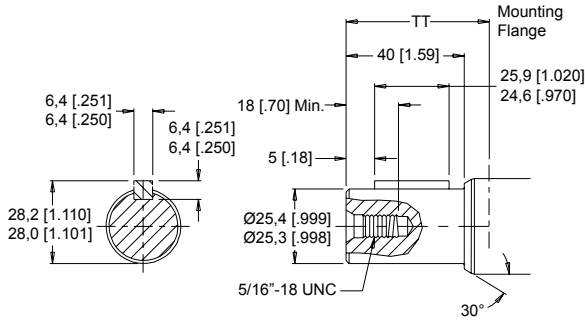

### 07 1-1/4" Straight

Max. Torque: 1200 Nm [10600 lb-in]

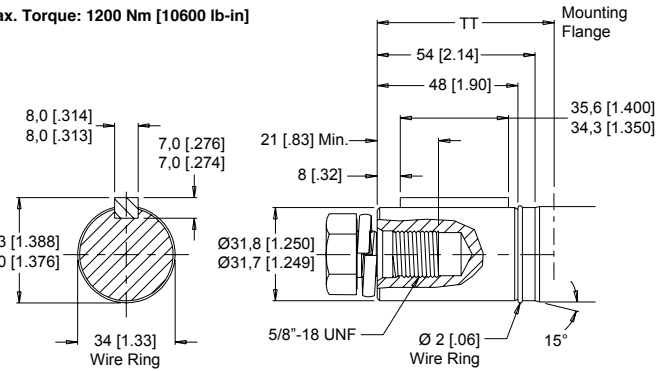

### 08 32mm Straight

Max. Torque: 1200 Nm [10600 lb-in]

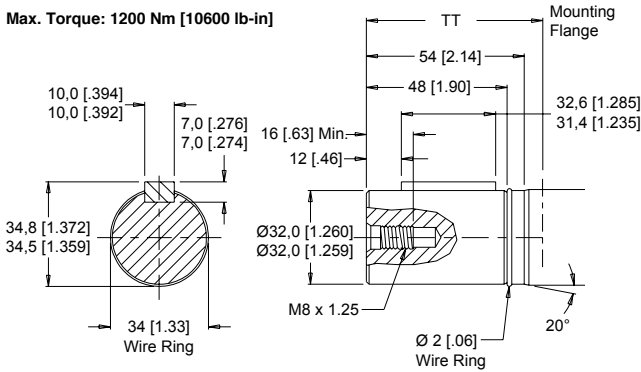

### 25 1-1/4" Tapered

Max. Torque: 1200 Nm [10600 lb-in]

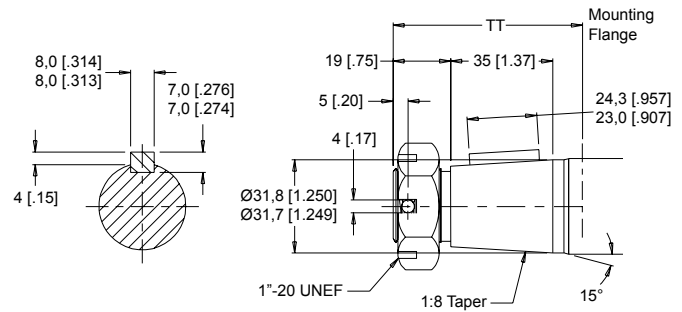

Note: A slotted nut is standard on this shaft.

### 03 6B Spline

Max. Torque: 429 Nm [3800 lb-in]

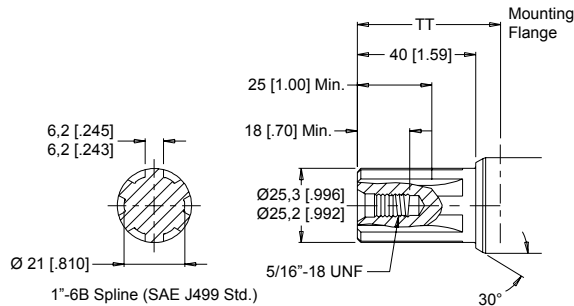

### 09 14 Tooth Spline

Max. Torque: 1200 Nm [10600 lb-in]

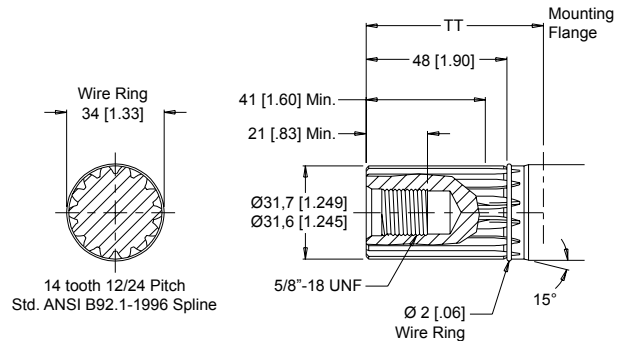

#### MOUNTING FLANGE TO SHAFT END Dimension TT

Code	SAE A Mount mm [in]	Wheel Mount mm [in]
03	67 [2.63]	135 [5.31]
07	63 [2.47]	131 [5.15]
08	62 [2.46]	130 [5.14]
09	63 [2.47]	131 [5.15]
15	51 [2.02]	119 [4.69]
25	51 [2.02]	119 [4.69]



520 & 521 SERIES MODEL CODE BUILDER

SERIES	DISPLACEMENT	HOUSING	SHAFT	PAINT	CAVITY	ADD ON	MISCELLANEOUS
STEP 1	STEP 2	STEP 3	STEP 4	STEP 5	STEP 6	STEP 7	STEP 8

STEP 1 - Select a series

- 520 Counterclockwise Rotation
- 521 Clockwise Rotation

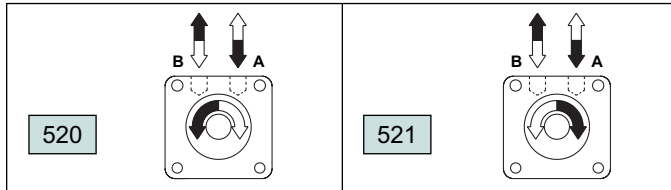

**NOTE:** For applications requiring the motor to rotate in only one direction, shaft seal life may be prolonged by pressurizing the "A" port of the motor. To obtain the desired direction of shaft rotation, use the graphic above to determine the rotation code for the motor. For bi-directional applications, the 520 series is recommended. Preferred rotation is determined by internal valving design.

STEP 2 - Select a displacement option

120	121 cc [7.4 in <sup>3</sup> /rev]	350	348 cc [21.2 in <sup>3</sup> /rev]
160	162 cc [9.9 in <sup>3</sup> /rev]	375	375 cc [22.8 in <sup>3</sup> /rev]
200	204 cc [12.4 in <sup>3</sup> /rev]	470	465 cc [28.3 in <sup>3</sup> /rev]
230	232 cc [14.2 in <sup>3</sup> /rev]	540	536 cc [32.7 in <sup>3</sup> /rev]
260	261 cc [15.9 in <sup>3</sup> /rev]	750	748 cc [45.6 in <sup>3</sup> /rev]
300	300 cc [18.3 in <sup>3</sup> /rev]		

STEP 3 - Select a housing option

- A51 6-Hole 7/8" O-Ring Aligned Ports
- A57 6-Hole Manifold Aligned Ports
- A58 6-Hole 1/2" BSP.F Aligned Ports
- W31 4-Hole 7/8" O-Ring Aligned Ports
- W38 4-Hole 1/2" BSP.F Aligned Ports

STEP 4 - Select a shaft option

- 03 6B Spline Extended
- 07 1-1/4" Straight Extended
- 08 32mm Straight Extended
- 09 14 Tooth Spline Extended
- 15 1" Straight Extended
- 25 1-1/4" Tapered Extended

STEP 5 - Select a paint option

- A Black
- B Black (unpainted flange face)
- Z No Paint

STEP 6 - Select a valve cavity option

- A None

STEP 7 - Select an add on option

- A Standard
- B Lock Nut
- C Solid Hex Nut

STEP 8 - Select a miscellaneous option

- AA None
- AC Freeturning Rotor
- AE Hydraulic Declutch with Freeturning Rotor





NOTE: Dimensions shown are without paint. Paint thickness can be up to 0,13 [.005]

530 & 531 SERIES HOUSINGS (WHEEL MOUNT)

**T31** 4-Hole 7/8" O-Ring Aligned Ports

**T38** 4-Hole 1/2" BSP.F Aligned Ports

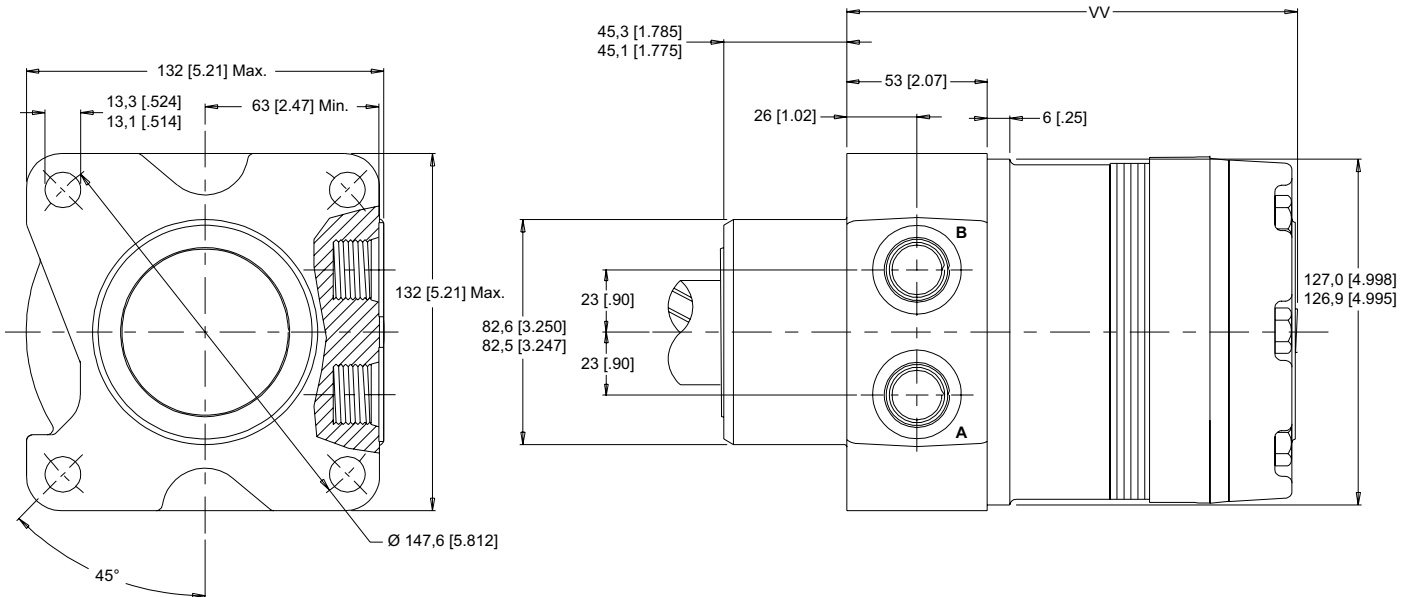

**Bearing Curve:** The bearing curve represents allowable bearing loads based on ISO 281 bearing capacity for an  $L_{10}$  life of 2,000 hours at 100 rpm. Radial loads for speeds other than 100 rpm may be calculated using the multiplication factor table located on page 11.

WHEEL MOUNT (LOWER SIDE LOAD CAPACITY)

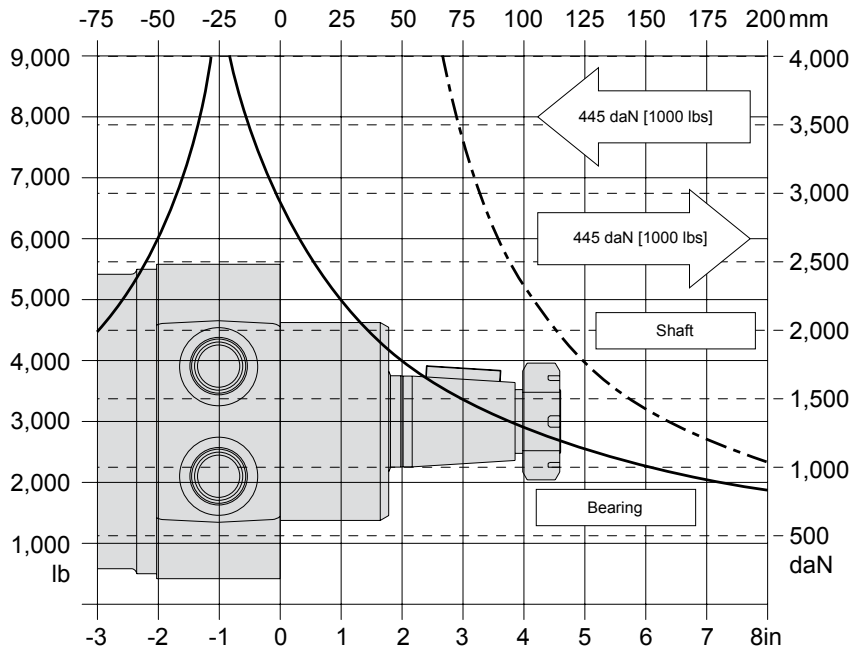

LENGTH / WEIGHT CHART Wheel Mount - Dimension VV		
Code	mm [in]	kg [lb]
120	156 [6.15]	14,9 [32.8]
160	156 [6.15]	14,9 [32.8]
200	159 [6.29]	15,2 [33.6]
230	162 [6.38]	15,3 [33.8]
260	165 [6.48]	15,6 [34.4]
300	168 [6.61]	16,0 [35.2]
350	182 [7.16]	17,1 [37.6]
375	174 [6.86]	16,5 [36.4]
470	182 [7.16]	17,1 [37.6]
540	188 [7.40]	17,6 [38.9]
750	206 [8.11]	19,0 [41.9]

NOTE:  
RE motor weights vary ± 0,5 kg [1 lb] depending upon motor configuration.



NOTE: Dimensions shown are without paint. Paint thickness can be up to 0,13 [.005]

## 530 & 531 SERIES HOUSINGS (WHEEL MOUNT)

**W31** 4-Hole 7/8" O-Ring Aligned Ports

**W38** 4-Hole 1/2" BSP.F Aligned Ports

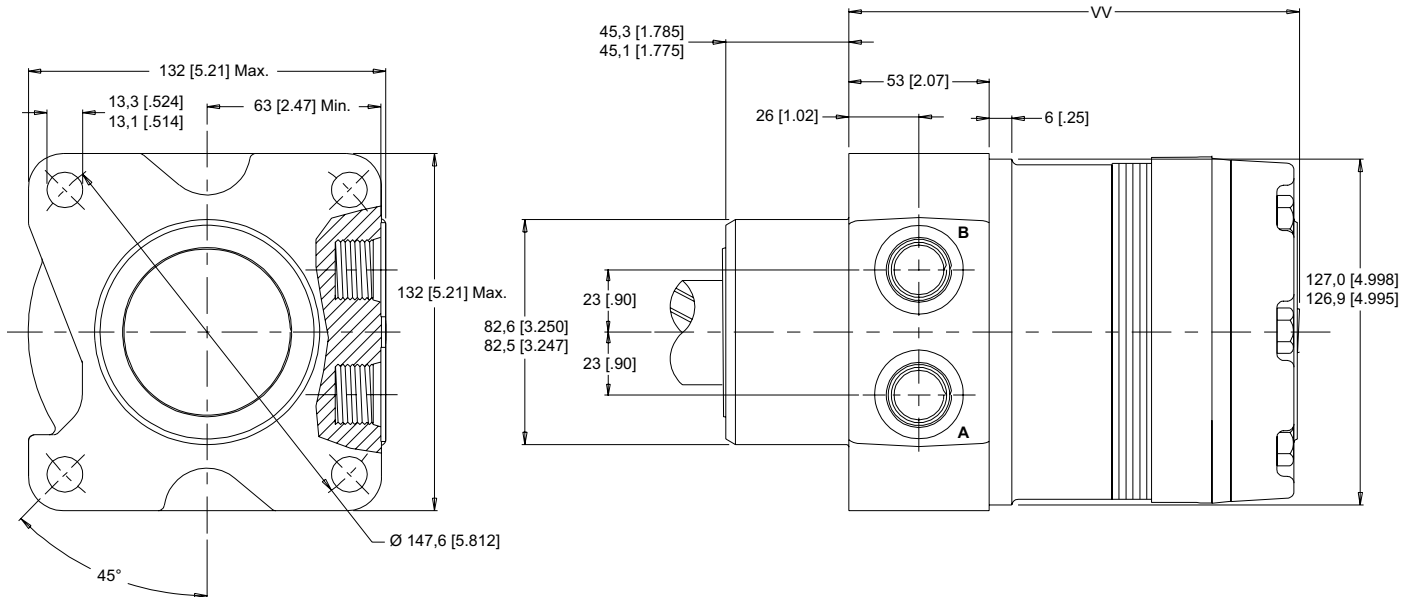

**Bearing Curve:** The bearing curve represents allowable bearing loads based on ISO 281 bearing capacity for an  $L_{10}$  life of 2,000 hours at 100 rpm. Radial loads for speeds other than 100 rpm may be calculated using the multiplication factor table located on page 11.

### WHEEL MOUNT

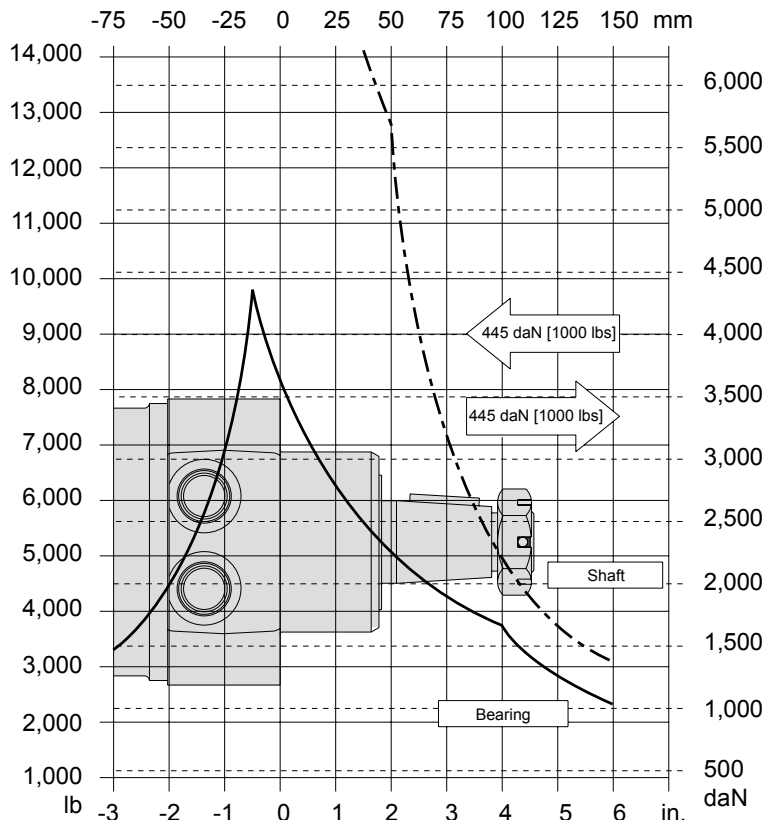

LENGTH / WEIGHT CHART		
Wheel Mount - Dimension VV		
Code	mm [in]	kg [lb]
120	156 [6.15]	14,9 [32.8]
160	156 [6.15]	14,9 [32.8]
200	159 [6.29]	15,2 [33.6]
230	162 [6.38]	15,3 [33.8]
260	165 [6.48]	15,6 [34.4]
300	168 [6.61]	16,0 [35.2]
350	182 [7.16]	17,1 [37.6]
375	174 [6.86]	16,5 [36.4]
470	182 [7.16]	17,1 [37.6]
540	188 [7.40]	17,6 [38.9]
750	206 [8.11]	19,0 [41.9]

NOTE:  
RE motor weights vary  $\pm 0,5$  kg [1 lb] depending upon motor configuration.



530 & 531 SERIES SHAFTS

**30** 1-1/2" Straight

Max. Torque: 1200 Nm [10600 lb-in]

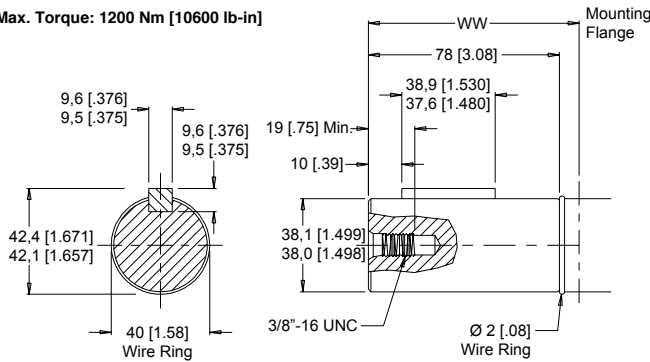

**31** 1-1/2" Tapered

Max. Torque: 1200 Nm [10600 lb-in]

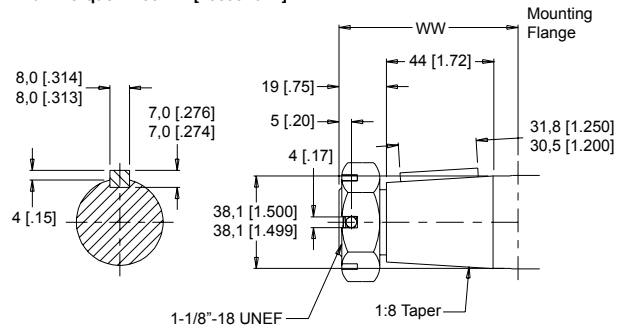

NOTE: A slotted nut is standard on this shaft.

**28** 35mm Tapered

Max. Torque: 1200 Nm [10600 lb-in]

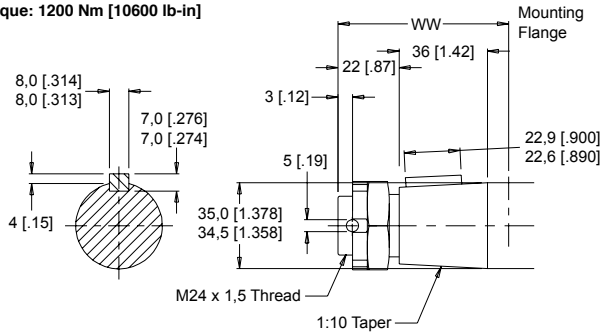

NOTE: Not available with the A51 and A58 housings only.

**27** 35mm Straight

Max. Torque: 1200 Nm [10600 lb-in]

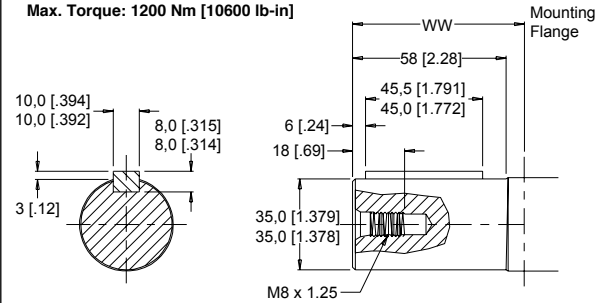

NOTE: Not available with the A51 and A58 housings only.



MOUNTING FLANGE TO SHAFT END Dimension WW		
Code	SAE A Mount mm [in]	Wheel Mount mm [in]
27	N/A	101 [3.97]
28	N/A	105 [4.14]
30	87 [3.42]	118 [4.63]
31	84 [3.32]	115 [4.53]



## 530 & 531 SERIES MODEL CODE BUILDER

SERIES	DISPLACEMENT	HOUSING	SHAFT	PAINT	CAVITY	ADD ON	MISCELLANEOUS
STEP 1	STEP 2	STEP 3	STEP 4	STEP 5	STEP 6	STEP 7	STEP 8

### STEP 1 - Select a series

- 530** Counterclockwise Rotation
- 531** Clockwise Rotation

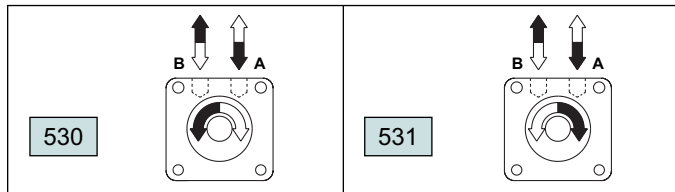

**NOTE:** For applications requiring the motor to rotate in only one direction, shaft seal life may be prolonged by pressurizing the "A" port of the motor. To obtain the desired direction of shaft rotation, use the graphic above to determine the rotation code for the motor. For bi-directional applications, the 530 series is recommended. Preferred rotation is determined by internal valving design.

### STEP 2 - Select a displacement option

<b>120</b>	121 cc [7.4 in <sup>3</sup> /rev]	<b>350</b>	348 cc [21.2 in <sup>3</sup> /rev]
<b>160</b>	162 cc [9.9 in <sup>3</sup> /rev]	<b>375</b>	375 cc [22.8 in <sup>3</sup> /rev]
<b>200</b>	204 cc [12.4 in <sup>3</sup> /rev]	<b>470</b>	465 cc [28.3 in <sup>3</sup> /rev]
<b>230</b>	232 cc [14.2 in <sup>3</sup> /rev]	<b>540</b>	536 cc [32.7 in <sup>3</sup> /rev]
<b>260</b>	261 cc [15.9 in <sup>3</sup> /rev]	<b>750</b>	748 cc [45.6 in <sup>3</sup> /rev]
<b>300</b>	300 cc [18.3 in <sup>3</sup> /rev]		

### STEP 3 - Select a housing option

- A51** 6-Hole 7/8" O-Ring Aligned Ports
- A58** 6-Hole 1/2" BSP.F Aligned Ports
- T31** 4-Hole 7/8" O-Ring Aligned Ports
- T38** 4-Hole 1/2" BSP.F Aligned Ports
- W31** 4-Hole 7/8" O-Ring Aligned Ports
- W38** 4-Hole 1/2" BSP.F Aligned Ports

### STEP 4 - Select a shaft option

- 27** 35mm Straight
- 28** 35mm Tapered
- 30** 1-1/2" Straight
- 31** 1-1/2" Tapered

### STEP 5 - Select a paint option

- A** Black
- B** Black (unpainted flange face)
- Z** No Paint

### STEP 6 - Select a valve cavity option

- A** None

### STEP 7 - Select an add on option

- A** Standard
- B** Lock Nut
- C** Solid Hex Nut

### STEP 8 - Select a miscellaneous option

- AA** None
- AC** Freeturning Rotor
- AE** Hydraulic Declutch with Freeturning Rotor



NOTE: Dimensions shown are without paint. Paint thickness can be up to 0,13 [.005]

### 510 & 511 SERIES MOTOR WITH MECHANICAL DRUM BRAKE

**X31** 4-Hole 7/8" O-Ring Aligned Ports

**X38** 4-Hole 1/2" BSP.F Aligned Ports

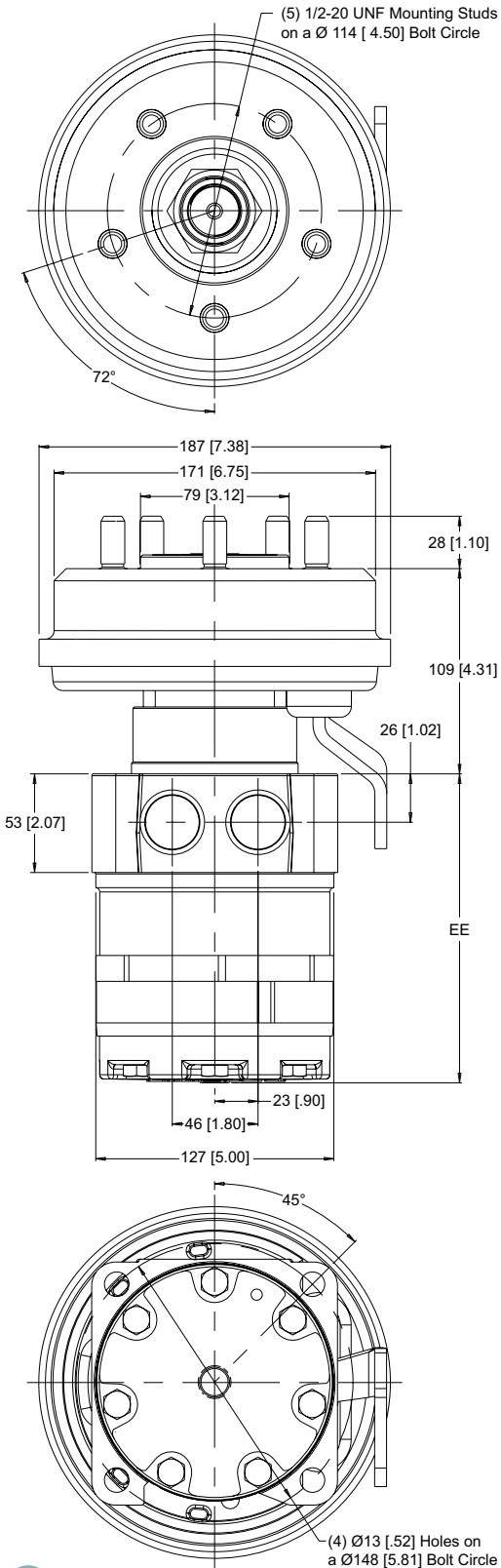

NOTE: Dimension EE is found on page 24.

#### OVERVIEW

**High Efficiency RE series Motor** provides exceptional low speed performance in one of the smallest wheel drive packages available today.

**Self-Adjusting Brake Mechanism** makes brake adjustments unnecessary by automatically adjusting for brake wear.

**Standard Wheel Mount Flange** adapts easily to new designs and can be retro-fitted onto older machines.

**4 and 5 Bolt Wheel Hubs** are available to accommodate a wide variety of wheel rims.

**Labyrinth Lip Design** incorporated into hub helps protect brake components from elements.

**2-Position Brake Lever** provides flexibility in the attachment of brake cables or actuating linkage.

#### TECHNICAL INFORMATION

**Bearing Curve:** The bearing curve represents allowable bearing loads based on ISO 281 bearing capacity for an  $L_{10}$  life of 2,000 hours at 100 rpm. Radial loads for speeds other than 100 rpm may be calculated using the multiplication factor table located on page 11.

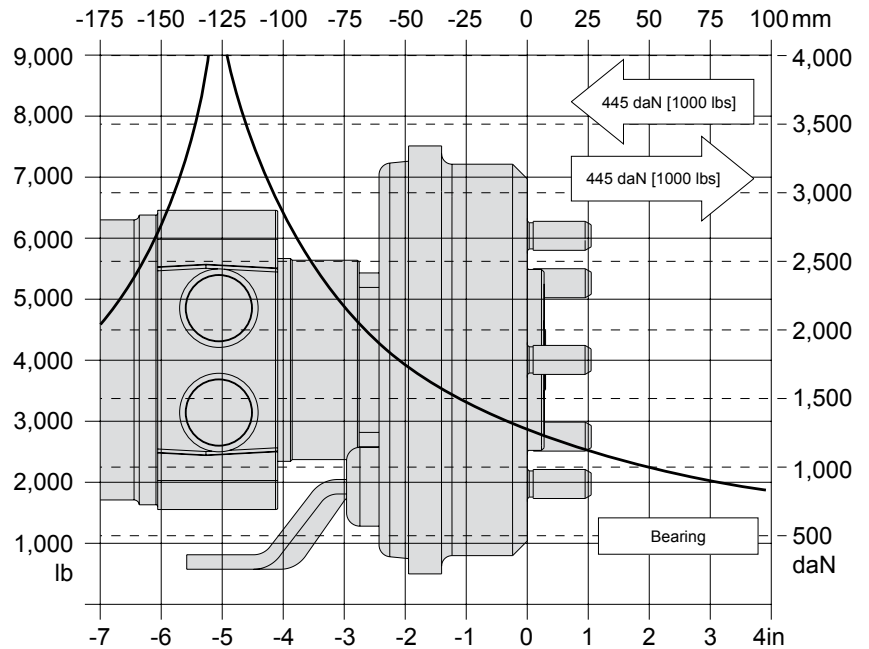



## 510 & 511 SERIES MODEL CODE BUILDER

### BRAKE HOLDING TORQUE

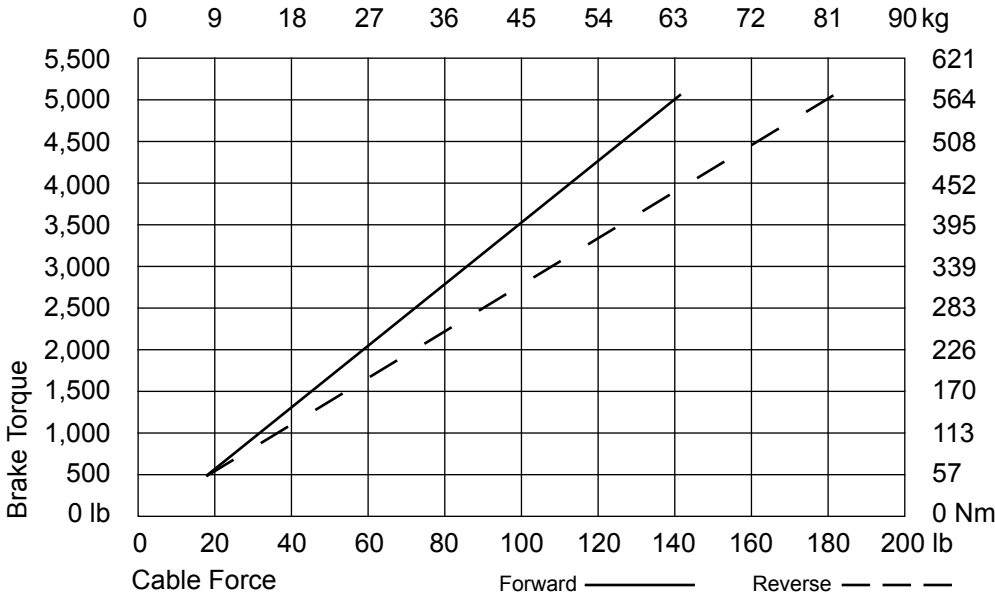

LENGTH / WEIGHT CHART Brake Mount - Dimension EE		
Code	mm [in]	kg [lb]
120	156 [6.15]	14,9 [42.9]
160	156 [6.15]	14,9 [42.9]
200	159 [6.29]	15,2 [43.7]
230	162 [6.38]	15,3 [43.9]
260	165 [6.48]	15,6 [44.5]
300	168 [6.61]	16,0 [45.3]
350	182 [7.16]	17,1 [47.7]
375	174 [6.86]	16,5 [46.5]
470	182 [7.16]	17,1 [47.7]
540	188 [7.40]	17,6 [49.0]
750	206 [8.11]	19,0 [52.0]

**NOTE:**  
RE motor weights vary ± 0,5 kg [1 lb] depending upon motor configuration.

SERIES	DISPLACEMENT	HOUSING	SHAFT	PAINT	CAVITY	ADD ON	MISCELLANEOUS
STEP 1	STEP 2	STEP 3	STEP 4	STEP 5	STEP 6	STEP 7	STEP 8

#### STEP 1 - Select a series

- 510** Counterclockwise Rotation
- 511** Clockwise Rotation

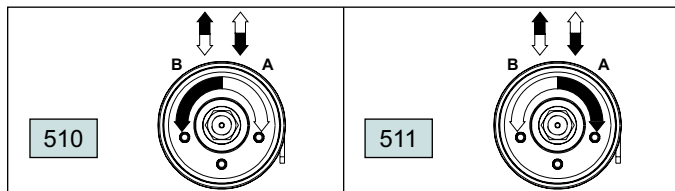

**NOTE:** For applications requiring the motor to rotate in only one direction, shaft seal life may be prolonged by pressurizing the "A" port of the motor. To obtain the desired direction of shaft rotation, use the graphic above to determine the rotation code for the motor. For bi-directional applications, the 510 series is recommended. Preferred rotation is determined by internal valving design.

#### STEP 2 - Select a displacement option

<b>120</b>	121 cc [7.4 in <sup>3</sup> /rev]	<b>350</b>	348 cc [21.2 in <sup>3</sup> /rev]
<b>160</b>	162 cc [9.9 in <sup>3</sup> /rev]	<b>375</b>	375 cc [22.8 in <sup>3</sup> /rev]
<b>200</b>	204 cc [12.4 in <sup>3</sup> /rev]	<b>470</b>	465 cc [28.3 in <sup>3</sup> /rev]
<b>230</b>	232 cc [14.2 in <sup>3</sup> /rev]	<b>540</b>	536 cc [32.7 in <sup>3</sup> /rev]
<b>260</b>	261 cc [15.9 in <sup>3</sup> /rev]	<b>750</b>	748 cc [45.6 in <sup>3</sup> /rev]
<b>300</b>	300 cc [18.3 in <sup>3</sup> /rev]		

#### STEP 3 - Select a housing option

- X31** 4-Hole 7/8" O-Ring Aligned Ports
- X38** 4-Hole 1/2" BSP.F Aligned Ports

#### STEP 4 - Select a shaft option

- 31** 1-1/2" Tapered

#### STEP 5 - Select a paint option

- A** Black
- Z** No Paint

#### STEP 6 - Select a valve cavity option

- A** None

#### STEP 7 - Select an add on option

- A** Standard

#### STEP 8 - Select a miscellaneous option

- YA** Brake Drum Right Hand Position 2, 5 Bolt Hub
- ZA** Brake Drum Left Hand Position 1, 5 Bolt Hub
- YE** Brake Drum Right Hand Position 2, 4 Bolt Hub
- ZE** Brake Drum Left Hand Position 1, 4 Bolt Hub



540 & 541 SERIES TECHNICAL INFORMATION

**W31** 4-Hole 7/8" O-Ring Aligned Ports

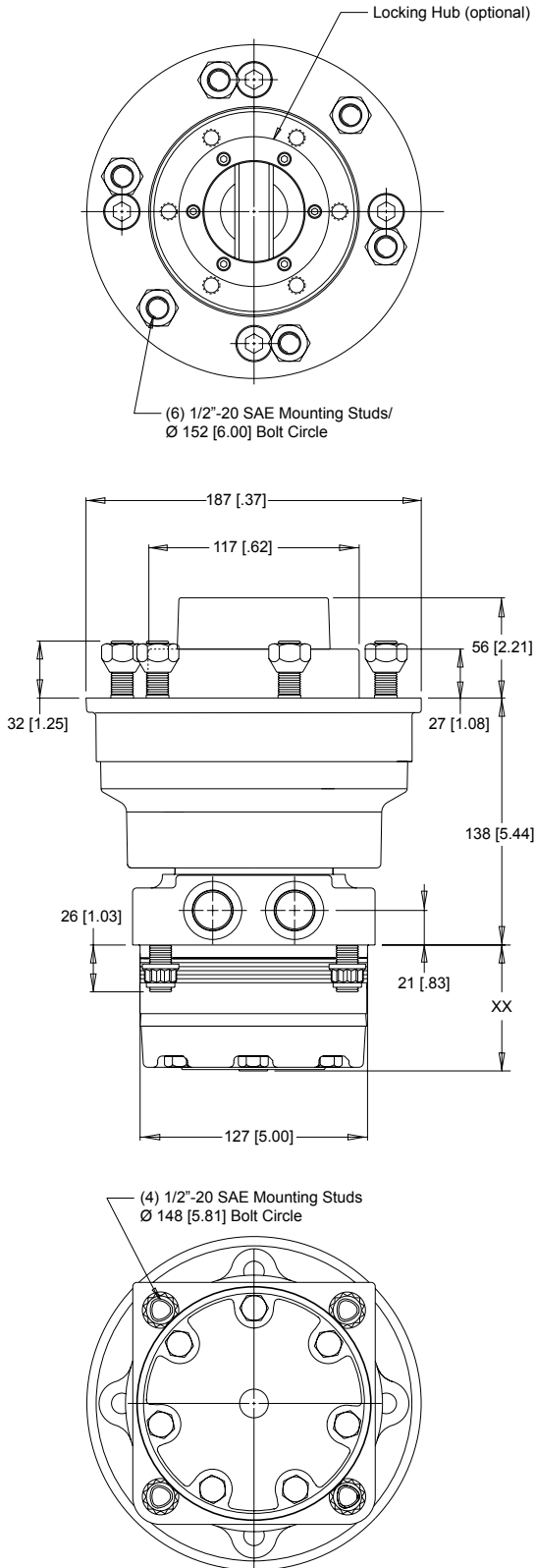

**Bearing Curve:** The bearing curve represents allowable bearing loads based on ISO 281 bearing capacity for an  $L_{10}$  life of 2,000 hours at 100 rpm. Radial loads for speeds other than 100 rpm may be calculated using the multiplication factor table located on page 11.

WHEEL MOUNT WITH 125MM BEARING

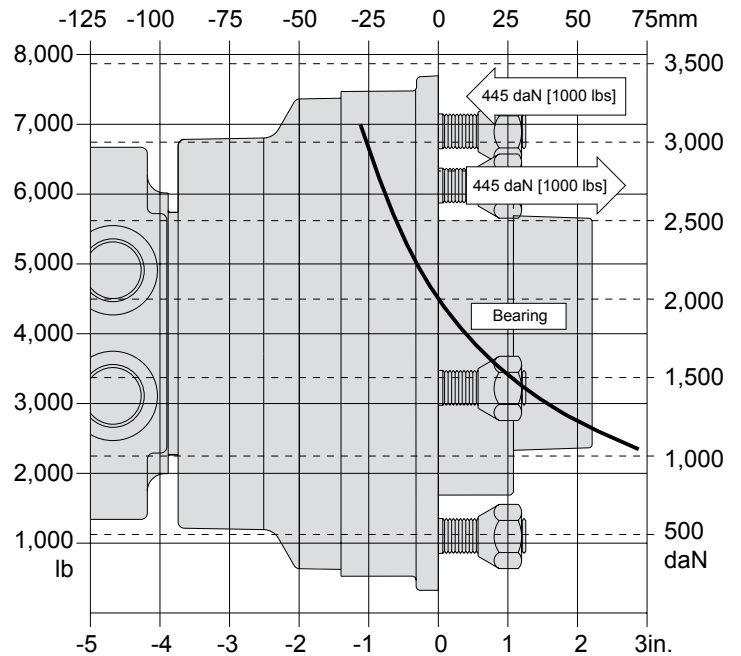

**LENGTH / WEIGHT CHART**  
Wheel Mount - Dimension XX

Code	mm [in]	kg [lb]
120	70 [2.77]	22,3 [49.1]
160	70 [2.77]	22,3 [49.1]
200	74 [2.90]	22,6 [49.9]
230	76 [2.99]	22,7 [50.1]
260	79 [3.09]	23,0 [50.7]
300	82 [3.22]	23,4 [51.5]
350	96 [3.77]	24,4 [53.9]
375	88 [3.47]	23,9 [52.7]
470	96 [3.77]	24,4 [53.9]
540	102 [4.01]	25,0 [55.1]
750	120 [4.72]	26,4 [58.2]

NOTE:  
RE motor weights vary  $\pm 0,5$  kg [1 lb] depending upon motor configuration.

# RE



## 540 & 541 SERIES MODEL CODE BUILDER

SERIES	DISPLACEMENT	HOUSING	SHAFT	PAINT	CAVITY	ADD ON	MISCELLANEOUS
STEP 1	STEP 2	STEP 3	STEP 4	STEP 5	STEP 6	STEP 7	STEP 8

### STEP 1 - Select a series

- 540 Counterclockwise Rotation
- 541 Clockwise Rotation

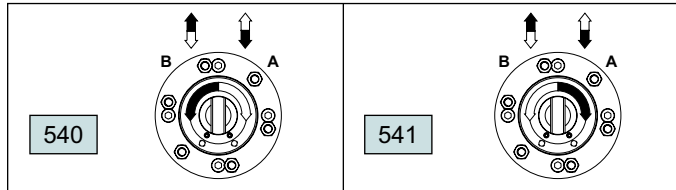

**NOTE:** For applications requiring the motor to rotate in only one direction, shaft seal life may be prolonged by pressurizing the "A" port of the motor. To obtain the desired direction of shaft rotation, use the graphic above to determine the rotation code for the motor. For bi-directional applications, the 540 series is recommended. Preferred rotation is determined by internal valving design.

### STEP 2 - Select a displacement option

120	121 cc [7.4 in <sup>3</sup> /rev]	350	348 cc [21.2 in <sup>3</sup> /rev]
160	162 cc [9.9 in <sup>3</sup> /rev]	375	375 cc [22.8 in <sup>3</sup> /rev]
200	204 cc [12.4 in <sup>3</sup> /rev]	470	465 cc [28.3 in <sup>3</sup> /rev]
230	232 cc [14.2 in <sup>3</sup> /rev]	540	536 cc [32.7 in <sup>3</sup> /rev]
260	261 cc [15.9 in <sup>3</sup> /rev]	750	748 cc [45.6 in <sup>3</sup> /rev]
300	300 cc [18.3 in <sup>3</sup> /rev]		

### STEP 3 - Select a housing option

- W31 4-Hole 7/8" O-Ring Aligned Ports

### STEP 4 - Select a shaft option

- 61 6-Bolt Wheel Flange

### STEP 5 - Select a paint option

- A Black
- Z No Paint

### STEP 6 - Select a valve cavity option

- A None

### STEP 7 - Select an add on option

- A Standard
- H Locking Hub

### STEP 8 - Select a miscellaneous option

- AA None
- AC Freeturning Rotor
- AE Hydraulic Declutch with Freeturning Rotor

### **Important Information**

Before selecting or using a White Drive Products' product, it is important that all information concerning the product warranty, limitation of liability and responsibility of the customer be reviewed. This information is located below. Please direct any questions regarding this information to your White Drive Products representative.

### **Disclaimer**

This catalog provides product options for further investigation by customers having technical expertise with respect to the use of such products. It is the responsibility of the customer to thoroughly analyze all aspects of the customer's application and to review the information concerning the product in the current product catalog. Due to the diversity of possible applications, the customer is solely responsible for making the final selection of the product(s) to be used and to assure that all performance, safety and warning requirements of the application are met. The customer is further responsible for all testing to verify acceptable life and performance of White Drive Products' products under actual operating conditions.

White Drive Products has made all reasonable efforts to present accurate information in this catalog and shall not be responsible for any incorrect information which may result from unintentional oversight. Due to continuous product improvement, the product specifications as stated in this catalog are subject to change by White Drive Products at any time without notice. The customer should consult a sales representative of White Drive Products for detailed information and to determine any changes in the information in this catalog.

Improper selection or improper use of the products described herein can result in death, personal injury and/or property damage. White Drive Products, Inc.'s sole responsibility with respect to its products is set forth in the warranty/limitation of liability policy state herein.

### **Warranty**

White Drive Products' products are sold subject to a limited warranty and a limitation of remedies policy, both of which constitute part of any and all agreements to purchase White Drive Products' products. White Drive Products makes no other warranties or promises other than those specifically noted in its written policies, and no White Drive Products employee or agent has the power to alter those policies other than in writing.

## **OTHER FINE PRODUCTS AVAILABLE FROM WHITE DRIVE PRODUCTS**



**A COMPLETE RANGE  
OF LSHT HYDRAULIC  
MOTORS**



**HYDRAULIC  
CONTROLLED  
PRESSURE  
RELEASED BRAKES**



**Delivering The Power To Get Work Done.**

### United States

White Drive Products, Inc.  
P.O. Box 1127  
Hopkinsville, KY. USA 42241  
Phone: +1.270.885.1110  
Fax: +1.270.886.8462  
[infousa@whitedriveproducts.com](mailto:infousa@whitedriveproducts.com)

### Germany

White Drive Products GmbH  
Mannsnetterstrasse 34 D-40880  
Opfenbach, Germany  
Phone: +49 8385 924988 0  
Fax: +49 8385 924988 9  
[infoeu@whitedriveproducts.com](mailto:infoeu@whitedriveproducts.com)

### China

White (China) Drive Products Co., Ltd.  
1-8 Ning Zhen Gong Lu  
Zhenjiang, 212021, Jiangsu, China  
Phone: +86 511 5729988  
Fax: +86 511 5728921  
[infochina@whitedriveproducts.com](mailto:infochina@whitedriveproducts.com)



**whitedriveproducts**

[www.whitedriveproducts.com](http://www.whitedriveproducts.com)