



DT

SERIES HYDRAULIC MOTORS

DT

OVERVIEW

The most amazing aspect of the DT Series motor is its huge torque potential from its relatively small size. The DT Series motor is capable of producing output torque comparable to competitive designs, but from a package that is both shorter and lighter. The savings in space and weight in no way compromises durability, as the motor uses massive shafts, bearings and drive links to transmit the torque produced by this powerful package. The use of a case drain allows reduced pressure on the shaft seal while maintaining driveline lubrication for maximum motor life. Standard mounting and shaft options offer interchangeability with competitive designs. An internal drain option is also available.

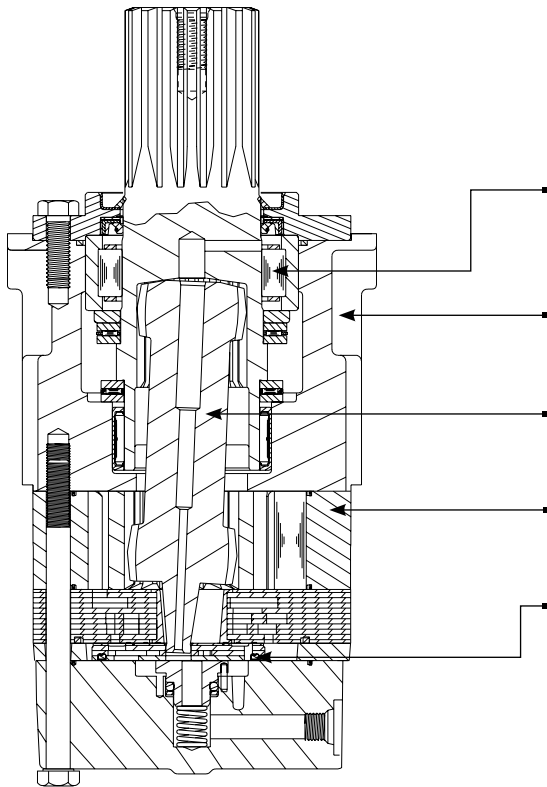

KEY FEATURES

- Heavy-Duty Roller Bearing** supports high side loads and receives forced lubrication for cooling and increased life.
- Compact Housing** contributes to high power-to-weight ratio of motor and offers front and rear mounting flanges.
- Heavy-Duty Drive Link** receives forced lubrication for long life and is capable of extreme duty cycles.
- Roller Stator® Motor** available in displacements up to 2093cc [127.7 cid] for high torque output.
- Three-Zone Orbiting Valve** precisely meters oil to produce exceptional volumetric efficiencies.

SPECIFICATIONS

Intermittent Ratings - 10% of Operation Peak Ratings - 1% of Operation

CODE	Displacement cc [in ³ /rev]	Max. Speed rpm		Max. Flow lpm [gpm]		Max. Torque Nm [lb-in]		Max. Pressure bar [psi]		
		cont.	inter.	cont.	inter.	cont.	inter.	cont.	inter.	peak
300	300 [18.3]	320	380	95 [25]	114 [30]	819 [7250]	955 [8450]	207 [3000]	241 [3500]	259 [3750]
375	374 [22.8]	250	300	95 [25]	114 [30]	1045 [9250]	1127 [9975]	207 [3000]	224 [3250]	241 [3500]
470	464 [28.3]	200	240	95 [25]	114 [30]	1071 [9475]	1390 [12300]	172 [2500]	224 [3250]	241 [3500]
540	536 [32.7]	180	210	95 [25]	114 [30]	1277 [11300]	1525 [13500]	172 [2500]	207 [3000]	241 [3500]
750	747 [45.6]	130	150	95 [25]	114 [30]	1780 [15750]	2090 [18500]	172 [2500]	207 [3000]	241 [3500]
930	929 [56.7]	100	120	95 [25]	114 [30]	1780 [15750]	2141 [18950]	138 [2000]	172 [2500]	207 [3000]
1K1	1047 [63.9]	90	110	95 [25]	114 [30]	1915 [16950]	2316 [20500]	138 [2000]	172 [2500]	207 [3000]
1K5	1495 [91.2]	60	70	95 [25]	114 [30]	2090 [18500]	2316 [20500]	103 [1500]	121 [1750]	138 [2000]
2K1	2093 [127.7]	40	50	95 [25]	114 [30]	2661 [23550]	3342 [29580]	103 [1500]	121 [1750]	138 [2000]



300

Pressure - bars [psi]						Max. Cont.	Max. Inter.
17 [250]	35 [500]	69 [1000]	104 [1500]	138 [2000]	173 [2500]	207 [3000]	241 [3500]

300 cc [18.3 in³/rev.]

Torque - Nm [lb-in], **Speed rpm** Intermittent Ratings - 10% of Operation

Flow - lpm [gpm]	2 [0.5]	54 [476] 4	115 [1014] 3	237 [2100] 2						7	Theoretical rpm
	4 [1]	47 [415] 11	108 [952] 9	255 [2256] 7	380 [3363] 5	486 [4304] 3				13	
	8 [2]	49 [435] 24	119 [1057] 23	257 [2278] 21	410 [3628] 19	543 [4801] 15	671 [5942] 12	789 [6983] 9	899 [7959] 7	26	
	15 [4]	49 [430] 50	120 [1064] 49	264 [2336] 46	409 [3616] 43	554 [4904] 37	701 [6202] 32	839 [7424] 28	971 [8595] 26	51	
	23 [6]		116 [1025] 75	278 [2462] 69	420 [3719] 65	567 [5019] 58	712 [6297] 54	854 [7554] 51	983 [8701] 48	76	
	30 [8]		105 [929] 100	251 [2222] 97	396 [3506] 93	542 [4793] 86	692 [6122] 78	831 [7353] 70	974 [8621] 69	101	
	38 [10]		99 [877] 126	237 [2099] 122	388 [3438] 115	549 [4857] 113	687 [6081] 107	833 [7369] 96	970 [8588] 90	127	
	45 [12]		88 [762] 151	237 [2094] 150	378 [3342] 140	527 [4666] 135	666 [5893] 129	823 [7281] 119	963 [8523] 113	152	
	53 [14]		77 [679] 176	211 [1864] 175	361 [3191] 172	506 [4478] 164	656 [5802] 156	805 [7121] 151	951 [8420] 140	177	
	61 [16]		60 [528] 201	208 [1845] 200	359 [3179] 189	495 [4378] 185	648 [5731] 178	791 [6999] 172	928 [8213] 165	202	
	68 [18]			191 [1694] 225	335 [2961] 222	497 [4402] 211	632 [5592] 206	776 [6871] 196	914 [8093] 189	228	
	76 [20]			168 [1489] 251	320 [2835] 247	461 [4083] 240	610 [5401] 233	764 [6762] 228	897 [7934] 216	253	
	83 [22]			147 [1298] 276	302 [2675] 272	444 [3926] 269	588 [5205] 258	742 [6570] 249	883 [7810] 234	278	
	91 [24]			123 [1086] 300	272 [2409] 298	414 [3666] 296	558 [4934] 290	708 [6264] 281	851 [7535] 272	303	
	95 [25]			108 [958] 315	257 [2278] 313	393 [3482] 308	549 [4857] 300	694 [6139] 289	839 [7421] 280	316	
	114 [30]				186 [1642] 376	333 [2945] 372	473 [4189] 369			379	

Overall Efficiency - 70 - 100% 40 - 69% 0 - 39%

Theoretical Torque - Nm [lb-in]

82 [729]	165 [1457]	329 [2914]	494 [4371]	659 [5828]	823 [7285]	988 [8742]	1152 [10199]
----------	------------	------------	------------	------------	------------	------------	--------------

Displacement tested at 54°C [129°F] with an oil viscosity of 46cSt [213 SUS]

Pressure - bars [psi]						Max. Cont.	Max. Inter.
17 [250]	35 [500]	69 [1000]	104 [1500]	138 [2000]	173 [2500]	207 [3000]	224 [3250]

375

374 cc [22.8 in³/rev.]

Torque - Nm [lb-in], **Speed rpm** Intermittent Ratings - 10% of Operation

Flow - lpm [gpm]	2 [0.5]	65 [574] 4	144 [1272] 3	302 [2670] 2	449 [3970] 1					6	Theoretical rpm
	4 [1]	66 [583] 9	152 [1345] 8	312 [2757] 7	475 [4208] 5	625 [5535] 4				11	
	8 [2]	67 [596] 19	154 [1365] 18	329 [2907] 17	496 [4388] 14	644 [5695] 12	805 [7122] 10	963 [8524] 8	1050 [9288] 7	21	
	15 [4]	71 [627] 40	158 [1400] 39	337 [2982] 37	513 [4536] 34	680 [6020] 30	858 [7596] 27	1013 [8962] 25	1099 [9723] 23	41	
	23 [6]	64 [570] 60	151 [1334] 60	336 [2969] 58	520 [4598] 54	694 [6141] 49	871 [7704] 45	1048 [9275] 41	1115 [9867] 41	61	
	30 [8]	53 [467] 81	151 [1337] 80	325 [2876] 78	512 [4532] 73	691 [6113] 69	873 [7724] 63	1051 [9304] 60	1126 [9964] 59	82	
	38 [10]		131 [1161] 101	313 [2768] 99	502 [4439] 95	686 [6075] 89	884 [7824] 82	1049 [9281] 79	1131 [10011] 77	102	
	45 [12]		112 [995] 121	308 [2725] 120	494 [4375] 116	685 [6059] 109	862 [7626] 103	1053 [9321] 98	1137 [10066] 97	122	
	53 [14]		99 [878] 141	283 [2508] 140	469 [4149] 136	645 [5705] 131	844 [7467] 125	1013 [8965] 117	1116 [9877] 115	142	
	61 [16]		75 [662] 162	262 [2319] 161	443 [3923] 160	631 [5587] 155	823 [7283] 148	1009 [8930] 143	1114 [9859] 136	163	
	68 [18]			248 [2198] 181	427 [3779] 178	612 [5416] 175	804 [7119] 167	1005 [8895] 160	1091 [9653] 156	183	
	76 [20]			218 [1925] 202	403 [3568] 200	583 [5161] 195	778 [6886] 189	966 [8549] 178	1071 [9474] 173	203	
	83 [22]			189 [1676] 222	375 [3318] 221	561 [4967] 217	754 [6669] 211	942 [8335] 201	1036 [9171] 196	223	
	91 [24]			155 [1374] 242	344 [3041] 240	535 [4732] 237	724 [6410] 229			244	
	95 [25]				321 [2839] 252	519 [4596] 249	710 [6283] 241			254	
	114 [30]				238 [2110] 303	432 [3820] 301	622 [5503] 296			304	

Overall Efficiency - 70 - 100% 40 - 69% 0 - 39%

Theoretical Torque - Nm [lb-in]

103 [908]	205 [1815]	410 [3631]	615 [5446]	821 [7261]	1026 [9076]	1231 [10892]	1333 [11799]
-----------	------------	------------	------------	------------	-------------	--------------	--------------

Displacement tested at 54°C [129°F] with an oil viscosity of 46cSt [213 SUS]



PERFORMANCE

470

Pressure - bars [psi]				Max. Cont.		Max. Inter.	
17 [250]	35 [500]	69 [1000]	104 [1500]	138 [2000]	173 [2500]	207 [3000]	224 [3250]

464 cc [28.3 in³/rev.]

Flow - lpm [gpm]	Torque - Nm [lb-in], Speed rpm								Intermittent Ratings - 10% of Operation		Theoretical rpm
	86 [762] 3	201 [1780] 2	401 [3553] 2								
2 [0.5]											5
4 [1]	92 [817] 7	195 [1728] 7	406 [3597] 6	610 [5395] 5	806 [7137] 4						9
8 [2]	94 [835] 15	199 [1761] 15	418 [3702] 14	631 [5580] 13	832 [7365] 11	1042 [9226] 9	1239 [10961] 8				17
15 [4]	92 [815] 32	202 [1784] 32	426 [3769] 60	646 [5717] 28	849 [7513] 24	1066 [9430] 23	1272 [11256] 21	1381 [12217] 19			33
23 [6]	82 [729] 48	203 [1799] 47	423 [3744] 46	647 [5725] 43	855 [7565] 39	1070 [9473] 36	1275 [11287] 34	1365 [12083] 32			49
30 [8]	67 [595] 65	185 [1641] 64	414 [3663] 63	642 [5683] 60	867 [7671] 54	1078 [9538] 47	1300 [11508] 46	1398 [12367] 44			66
38 [10]	52 [459] 81	170 [1503] 80	399 [3532] 79	630 [5573] 78	857 [7584] 69	1077 [9531] 63	1283 [11352] 61	1393 [12323] 58			82
45 [12]		153 [1354] 97	380 [3366] 96	613 [5422] 93	842 [7454] 88	1072 [9488] 77	1302 [11523] 74	1394 [12334] 68			98
53 [14]		127 [1121] 114	359 [3173] 113	591 [5229] 110	823 [7282] 104	1057 [9350] 97	1270 [11242] 89	1392 [12318] 85			115
61 [16]		100 [888] 160	335 [2964] 129	564 [4993] 127	798 [7061] 119	1030 [9118] 114	1254 [11101] 108	1369 [12118] 102			131
68 [18]		67 [595] 146	304 [2689] 145	535 [4734] 143	765 [6772] 137	1003 [8875] 132	1229 [10877] 120	1348 [11926] 114			147
76 [20]			274 [2428] 162	504 [4458] 160	733 [6485] 155	965 [8536] 148	1197 [10592] 139	1318 [11668] 136			164
83 [22]			226 [2003] 178	458 [4050] 175	691 [6118] 172	928 [8215] 165	1150 [10181] 156	1266 [11200] 154			180
91 [24]			176 [1554] 194	415 [3670] 192	669 [5917] 190	885 [7833] 183					196
95 [25]				389 [3442] 203	632 [5589] 198	867 [7676] 190					205
114 [30]				277 [2451] 243	514 [4549] 240	755 [6684] 235					245

Overall Efficiency - 70 - 100% 40 - 69% 0 - 39%

Theoretical Torque - Nm [lb-in]

127 [1127]	255 [2253]	509 [4506]	764 [6760]	1018 [9013]	1273 [1126]	1528 [13519]	1655 [14646]
------------	------------	------------	------------	-------------	-------------	--------------	--------------

Displacement tested at 54°C [129°F] with an oil viscosity of 46cSt [213 SUS]

Pressure - bars [psi] Max. Cont. Max. Inter.

540

17 [250]	35 [500]	69 [1000]	104 [1500]	138 [2000]	173 [2500]	207 [3000]
----------	----------	-----------	------------	------------	------------	------------

536 cc [32.7 in³/rev.]

Flow - lpm [gpm]	Torque - Nm [lb-in], Speed rpm								Intermittent Ratings - 10% of Operation		Theoretical rpm
	103 [908] 2	215 [1607] 2	421 [3722] 1								
2 [0.5]											4
4 [1]	104 [917] 6	228 [2016] 5	454 [4015] 4	666 [5897] 3	874 [7730] 1						8
8 [2]	108 [954] 13	231 [2043] 12	474 [4191] 11	704 [6231] 9	925 [8190] 5	1153 [10201] 4					15
15 [4]	102 [906] 27	232 [2052] 26	503 [4448] 24	756 [6692] 21	994 [8799] 18	1221 [10806] 15	1461 [12930] 13				29
23 [6]	98 [866] 42	230 [2038] 41	498 [4404] 39	766 [6774] 36	1023 [9049] 30	1268 [11225] 27	1494 [13219] 24				43
30 [8]	84 [744] 56	213 [1883] 55	484 [4280] 53	754 [6669] 49	1032 [9130] 42	1273 [11262] 38	1524 [13486] 34				57
38 [10]	63 [561] 70	195 [1727] 69	466 [4122] 68	737 [6519] 64	1006 [8903] 57	1285 [11374] 49	1532 [13556] 46				71
45 [12]	42 [373] 84	179 [1586] 83	444 [3928] 82	717 [6349] 76	984 [8710] 72	1274 [11277] 65	1518 [13436] 57				85
53 [14]		146 [1295] 97	421 [3722] 95	694 [6139] 93	964 [8529] 87	1253 [11091] 80	1512 [13381] 70				99
61 [16]		116 [1025] 113	391 [3460] 111	663 [5865] 108	930 [8230] 103	1206 [10675] 97	1479 [13086] 84				114
68 [18]		90 [798] 127	356 [3153] 125	629 [5563] 123	900 [7969] 116	1192 [10550] 107	1451 [12841] 100				128
76 [20]		56 [498] 141	330 [2923] 139	595 [5265] 137	887 [7850] 133	1158 [10250] 123	1421 [12578] 114				142
83 [22]			278 [2464] 155	549 [4859] 153	822 [7271] 148	1121 [9919] 136	1388 [12283] 133				156
91 [24]			243 [2154] 169	508 [4494] 166	794 [7024] 164	1054 [9325] 156					170
95 [25]			220 [1948] 176	486 [4299] 174	762 [6741] 169	1025 [9075] 163					177
114 [30]			90 [800] 211	366 [3237] 210	638 [5649] 207	920 [8144] 203					212

Overall Efficiency - 70 - 100% 40 - 69% 0 - 39%

Theoretical Torque - Nm [lb-in]

147 [1302]	294 [2604]	588 [5207]	883 [7811]	1177 [10414]	1471 [13018]	1765 [15621]
------------	------------	------------	------------	--------------	--------------	--------------

Displacement tested at 54°C [129°F] with an oil viscosity of 46cSt [213 SUS]



750

Pressure - bars [psi]						Max. Cont.	Max. Inter.
17 [250]	35 [500]	69 [1000]	104 [1500]	138 [2000]	173 [2500]	207 [3000]	

747 cc [45.6 in³/rev.]

Torque - Nm [lb-in], Speed rpm Intermittent Ratings - 10% of Operation

Flow - lpm [gpm]	2 [0.5]	144 [1276] 1	290 [2566] 1							3	Theoretical rpm
	4 [1]	154 [1367] 4	323 [2863] 3	669 [5917] 2	931 [8242] 2					6	
	8 [2]	162 [1435] 9	341 [3015] 9	712 [6302] 7	1021 [9038] 6	1305 [11550] 3				11	
	15 [4]	158 [1400] 19	348 [3080] 19	723 [6399] 17	1082 [9578] 15	1402 [12410] 11				21	
	23 [6]	144 [1273] 30	331 [2927] 29	714 [6317] 27	1083 [9583] 24	1433 [12678] 20	1744 [15430] 16			31	
	30 [8]	126 [1116] 40	328 [2900] 39	697 [6167] 37	1072 [9486] 34	1451 [12843] 25	1769 [15658] 20			41	
	38 [10]	104 [922] 50	291 [2574] 50	675 [5976] 47	1055 [9334] 44	1445 [12785] 36	1786 [15805] 28	2076 [18373] 19		51	
	45 [12]	77 [682] 60	269 [2382] 59	655 [5792] 58	1032 [9136] 54	1431 [12668] 49	1786 [15801] 36	2094 [18528] 30		61	
	53 [14]	46 [410] 70	239 [2116] 69	627 [5545] 68	1003 [8880] 65	1407 [12451] 59	1767 [15634] 45	2099 [18578] 37		71	
	61 [16]		201 [1780] 81	584 [5164] 79	971 [8592] 76	1345 [11907] 70	1743 [15422] 57	2065 [18271] 44		82	
	68 [18]		161 [1421] 91	545 [4819] 90	928 [8209] 86	1306 [11556] 80	1709 [15120] 69			92	
	76 [20]		120 [1058] 101	497 [4395] 100	863 [7635] 97	1260 [11154] 90				102	
	83 [22]			444 [3926] 110	831 [7351] 108	1213 [10737] 101				112	
	91 [24]			389 [3447] 121	785 [6947] 117	1196 [10581] 111				122	
	95 [25]			368 [3255] 126	757 [6697] 124	1144 [10126] 120				127	
	114 [30]			205 [1813] 151	613 [5428] 149	979 [8665] 146				152	

Overall Efficiency - 70 - 100% 40 - 69% 0 - 39%

Theoretical Torque - Nm [lb-in]

205 [1815]	410 [3631]	821 [7261]	1231 [10892]	1641 [14522]	2051 [18153]	2462 [21783]
------------	------------	------------	--------------	--------------	--------------	--------------

Displacement tested at 54°C [129°F] with an oil viscosity of 46cSt [213 SUS]

Pressure - bars [psi]						Max. Cont.	Max. Inter.
17 [250]	35 [500]	52 [750]	69 [1000]	86 [1250]	104 [1500]	121 [1750]	138 [2000]
							155 [2250]
							173 [2500]

930

929 cc [56.7 in³/rev.]

Torque - Nm [lb-in], Speed rpm Intermittent Ratings - 10% of Operation

Flow - lpm [gpm]	2 [0.5]	180 [1590] 1	387 [3423] 1	607 [5368] 1	801 [7089] 1						3	Theoretical rpm
	4 [1]	196 [1734] 4	418 [3696] 3	653 [5780] 3	864 [7649] 3	1067 [9447] 3	1294 [11451] 3				5	
	8 [2]	205 [1816] 8	442 [3907] 7	680 [6015] 7	877 [7764] 7	1117 [9886] 7	1300 [11501] 6	1510 [13365] 5			9	
	15 [4]	198 [1753] 16	432 [3825] 16	664 [5878] 15	906 [8021] 15	1121 [9924] 15	1338 [11840] 14	1556 [13769] 13	1730 [15306] 11		17	
	23 [6]	185 [1633] 24	420 [3719] 24	651 [5765] 24	908 [8034] 24	1123 [9935] 23	1355 [11991] 22	1543 [13651] 20	1794 [15873] 18	1981 [17532] 16	25	
	30 [8]	162 [1438] 32	404 [3576] 31	636 [5624] 30	893 [7900] 30	1107 [9800] 29	1340 [11854] 28	1581 [13988] 27	1776 [15716] 24	1985 [17570] 22	2105 [18632] 17	
	38 [10]	125 [1109] 40	368 [3253] 40	626 [5536] 39	845 [7476] 38	1087 [9620] 38	1314 [11625] 36	1497 [13251] 34	1736 [15364] 31	1956 [17306] 28	2153 [19054] 24	
	45 [12]	91 [807] 48	341 [3018] 47	578 [5111] 46	815 [7213] 45	1072 [9487] 44	1314 [11630] 42	1525 [13492] 41	1713 [15159] 36	1946 [17222] 33	2133 [18873] 32	
	53 [14]	35 [310] 57	290 [2565] 55	533 [4715] 55	765 [6772] 54	1024 [9059] 52	1240 [10974] 50	1487 [13155] 49	1727 [15287] 45	1945 [17216] 43	2168 [19188] 36	
	61 [16]		239 [2118] 64	484 [4281] 63	726 [6429] 62	959 [8488] 61	1210 [10708] 59	1450 [12830] 57	1696 [15008] 54	1925 [17039] 50	2140 [18934] 46	
	68 [18]		205 [1811] 72	440 [3891] 72	701 [6202] 70	920 [8143] 69	1177 [10418] 67	1422 [12580] 65	1643 [14538] 64	1893 [16741] 58	2105 [18625] 55	
	76 [20]		150 [1325] 81	409 [3616] 80	632 [5590] 79	801 [7091] 78	1100 [9733] 76	1505 [12135] 75	1599 [14148] 72	1859 [16454] 67	2060 [18230] 63	
	83 [22]		99 [875] 89	336 [2977] 88	581 [5139] 87	837 [7403] 86	1056 [9342] 83	1305 [11553] 83	1561 [13816] 80	1799 [15918] 77	2025 [17925] 71	
	91 [24]			282 [2497] 97	501 [4438] 96	766 [6778] 94	1021 [9038] 93	1266 [11201] 92	1489 [13179] 89	1752 [15505] 86	1969 [17427] 82	
	95 [25]			241 [2137] 101	496 [4389] 100	722 [6390] 100	974 [8621] 97	1214 [10743] 96	1454 [12863] 93	1727 [15286] 89	1956 [17309] 84	
	114 [30]			66 [582] 122	300 [2652] 121	532 [4711] 120	781 [6914] 118	1044 [9235] 118	1271 [11248] 116			

Overall Efficiency - 70 - 100% 40 - 69% 0 - 39%

Theoretical Torque - Nm [lb-in]

255 [2257]	510 [4514]	765 [6771]	1020 [9029]	1275 [11286]	1530 [13543]	1785 [15800]	2040 [18057]	2296 [20314]	2551 [22572]
------------	------------	------------	-------------	--------------	--------------	--------------	--------------	--------------	--------------

Displacement tested at 54°C [129°F] with an oil viscosity of 46cSt [213 SUS]



PERFORMANCE

		Pressure - bars [psi]								Max. Cont.	Max. Inter.
1K1		17 [250]	35 [500]	52 [750]	69 [1000]	86 [1250]	104 [1500]	121 [1750]	138 [2000]	155 [2250]	173 [2500]

1047 cc [63.9 in³/rev.] **Intermittent Ratings - 10% of Operation**

Flow - lpm [gpm]	Torque - Nm [lb-in], Speed rpm										Theoretical rpm						
	2 [0.5]	4 [1]	8 [2]	15 [4]	23 [6]	30 [8]	38 [10]	45 [12]	53 [14]	61 [16]		68 [18]	76 [20]	83 [22]	91 [24]	95 [25]	114 [30]
	217 [1918] 1	455 [4026] 1	671 [5940] 0.9	890 [7879] 0.6													2
	206 [1821] 3	498 [4410] 2	706 [6251] 2	935 [8273] 2	1189 [10518] 2												4
	224 [1985] 6	498 [4407] 6	754 [6672] 6	983 [8700] 5	1222 [10810] 5	1428 [12635] 4											8
	224 [1980] 14	472 [4180] 13	754 [6669] 13	1011 [8946] 13	1262 [11169] 11	1486 [13147] 10	1697 [15014] 9										15
	170 [1500] 21	487 [4314] 21	739 [6538] 20	1020 [9023] 19	1238 [10956] 18	1501 [13286] 16	1695 [14998] 14	1914 [16936] 12									22
	164 [1451] 28	431 [3814] 28	709 [6270] 28	970 [8580] 27	1241 [10986] 26	1481 [13106] 23	1727 [15280] 20	1942 [17185] 16	2144 [18971] 9								29
	129 [1143] 36	401 [3546] 36	675 [5975] 35	944 [8356] 34	1208 [10688] 32	1455 [12879] 29	1714 [15168] 26	1919 [16982] 26	2145 [18983] 17								37
	98 [871] 43	359 [3176] 43	624 [5526] 42	894 [7915] 41	1148 [10163] 40	1420 [12569] 37	1693 [14981] 31	1893 [16756] 25	2133 [18879] 22	2311 [20456] 19							44
	44 [390] 50	312 [2761] 50	580 [5129] 49	851 [7535] 49	1122 [9933] 47	1383 [12237] 44	1612 [14263] 40	1856 [16424] 33	2098 [18569] 29	2327 [20596] 25							51
		251 [2220] 57	516 [4569] 56	776 [6871] 56	1062 [9402] 55	1320 [11678] 52	1587 [14045] 50	1837 [16261] 38	2082 [18426] 30	2291 [20275] 29							58
		190 [1678] 65	458 [4053] 65	706 [6252] 64	1002 [8869] 62	1272 [11252] 60	1552 [13738] 59	1794 [15877] 52	2051 [18147] 41	2275 [20130] 33							66
		117 [1033] 72	390 [3453] 71	652 [5774] 71	930 [8227] 70	1187 [10502] 69	1596 [12874] 64	1723 [15246] 58	2001 [17705] 57	2228 [19716] 45							73
		50 [444] 79	310 [2741] 79	569 [5034] 78	847 [7493] 77	1113 [9846] 76	1380 [12214] 74	1650 [14599] 67	1927 [17055] 62	2138 [18924] 51							80
			210 [1862] 86	491 [4346] 85	755 [6677] 84	1018 [9007] 83	1288 [11398] 81	1557 [13777] 76	1827 [16164] 71	2101 [18591] 61							87
			185 [1635] 90	463 [4096] 90	710 [6281] 89	963 [8519] 88	1232 [10901] 85	1497 [13247] 82	1790 [15844] 76	2028 [17950] 71							91
				202 [1789] 108	477 [4217] 107	730 [6460] 106	1013 [8962] 105	1237 [10947] 104									109

Overall Efficiency - 70 - 100% 40 - 69% 0 - 39%

Theoretical Torque - Nm [lb-in]

287 [2544]	575 [5088]	862 [7631]	1150 [10175]	1437 [12719]	1725 [15263]	2012 [17807]	2300 [20350]	2587 [22894]	2874 [25438]
------------	------------	------------	--------------	--------------	--------------	--------------	--------------	--------------	--------------

Displacement tested at 54°C [129°F] with an oil viscosity of 46cSt [213 SUS]

Pressure - bars [psi] Max. Cont. Max. Inter.

		Pressure - bars [psi]								Max. Cont.	Max. Inter.
1K5		17 [250]	35 [500]	52 [750]	69 [1000]	86 [1250]	104 [1500]	121 [1750]			

1495 cc [91.2 in³/rev.] **Intermittent Ratings - 10% of Operation**

Flow - lpm [gpm]	Torque - Nm [lb-in], Speed rpm										Theoretical rpm						
	2 [0.5]	4 [1]	8 [2]	15 [4]	23 [6]	30 [8]	38 [10]	45 [12]	53 [14]	61 [16]		68 [18]	76 [20]	83 [22]	91 [24]	95 [25]	114 [30]
	305 [2703] 0.9	648 [5736] 0.6															2
	336 [2978] 2	693 [6128] 1	1011 [8942] 1														3
	351 [3106] 4	729 [6454] 4	1085 [9597] 3	1364 [12072] 3													6
	331 [2925] 9	712 [6304] 9	1116 [9879] 8	1491 [13191] 7	1771 [15668] 7												11
	297 [2629] 15	681 [3023] 14	1088 [9632] 13	1464 [12952] 12	1770 [15662] 10												16
	247 [2183] 20	640 [5662] 19	1038 [9188] 18	1430 [12655] 17	1793 [15864] 15	2123 [18786] 9											21
	197 [1740] 25	583 [5159] 24	1001 [8860] 23	1377 [12189] 22	1749 [15479] 19	2090 [18498] 14											26
	131 [1157] 30	531 [4695] 29	940 [8315] 28	1330 [11770] 27	1702 [15066] 24	2041 [18059] 19	2329 [20613] 14										31
	67 [594] 36	484 [4282] 35	869 [7689] 33	1267 [11217] 32	1642 [14532] 30	1990 [17612] 24	2300 [20353] 15										36
		391 [3457] 40	769 [6805] 39	1172 [10374] 37	1567 [13866] 36	1914 [16941] 32	2258 [19986] 21										41
		294 [2602] 45	686 [6072] 44	1076 [9523] 43	1489 [13177] 40	1846 [16334] 38	2188 [19366] 27										46
		182 [1607] 50	614 [5435] 49	988 [8746] 48	1392 [12320] 47	1743 [15429] 44	2301 [18553] 37										51
		87 [770] 55	487 [4310] 54	872 [7720] 53	1283 [11356] 52	1632 [14442] 48	2021 [17883] 46										56
			456 [4032] 60	749 [6632] 60	1146 [10143] 58	1533 [13570] 58	1872 [16568] 50										61
			293 [2589] 63	704 [6232] 62	1052 [9313] 62	1465 [12961] 59	1843 [16306] 53										64
				246 [2174] 75	645 [5711] 74	1047 [9265] 73											76

Overall Efficiency - 70 - 100% 40 - 69% 0 - 39%

Theoretical Torque - Nm [lb-in]

410 [3631]	821 [7261]	1231 [10892]	1641 [14522]	2051 [18153]	2462 [21783]	2872 [25414]
------------	------------	--------------	--------------	--------------	--------------	--------------

Displacement tested at 54°C [129°F] with an oil viscosity of 46cSt [213 SUS]



2K1

Pressure - bars [psi]					Max. Cont.	Max. Inter.
17 [250]	35 [500]	52 [750]	69 [1000]	86 [1250]	104 [1500]	121 [1750]

2093 cc [127.7 in³/rev.]

Torque - Nm [lb-in], Speed rpm Intermittent Ratings - 10% of Operation

Flow - lpm [gpm]	2 [0.5]	438 [3878] 0.8	892 [7894] 0.8							Theoretical rpm
	4 [1]	440 [3891] 1	922 [8162] 1	1398 [12375] 1						
	8 [2]	460 [4073] 3	956 [8458] 3	1460 [12923] 3						
	15 [4]	443 [3920] 7	963 [8525] 7	1491 [13192] 6	1980 [17520] 6					
	23 [6]	402 [3560] 10	924 [8179] 10	1470 [13012] 10	1963 [17370] 9					
	30 [8]	337 [2985] 14	884 [7824] 14	1425 [12613] 14	1920 [16995] 13	2390 [21152] 9	2668 [23613] 8			
	38 [10]	275 [2431] 17	814 [7205] 17	1350 [11944] 16	1869 [16538] 16	2343 [20733] 13	2663 [23564] 9			
	45 [12]	173 [1535] 21	723 [6398] 21	1262 [11171] 21	1795 [15886] 20	2286 [20232] 17	2665 [23588] 12			
	53 [14]	66 [587] 25	619 [5479] 24	1155 [10221] 24	1702 [15063] 23	2206 [19519] 21	2637 [23333] 13			
	61 [16]		496 [4391] 28	1018 [9009] 28	1587 [14046] 27	2107 [18645] 26	2574 [22777] 20			
	68 [18]		368 [3257] 32	910 [8052] 32	1466 [12973] 31	1980 [17527] 30	2471 [21866] 26			
	76 [20]		225 [1991] 36	755 [6686] 36	1304 [11537] 36	1859 [16449] 35	2359 [20878] 30			
	83 [22]		71 [628] 39	622 [5507] 39	1171 [10367] 39	1682 [14885] 38	2212 [19575] 36			
	91 [24]			429 [3794] 43	984 [8704] 43	1544 [13665] 42	2067 [18291] 40			
	95 [25]			354 [3129] 45	891 [7883] 45	1428 [12636] 45	1971 [17445] 43			
	114 [30]				430 [3803] 54	959 [8485] 54	1492 [13207] 53			

Overall Efficiency - 70 - 100% 40 - 69% 0 - 39%

Theoretical Torque - Nm [lb-in]

574 [5084]	1149 [10167]	1723 [15251]	2298 [20334]	2872 [25418]	3447 [30502]	4021 [35585]
------------	--------------	--------------	--------------	--------------	--------------	--------------

Displacement tested at 54°C [129°F] with an oil viscosity of 46cSt [213 SUS]



NOTE: Dimensions shown are without paint. Paint thickness can be up to 0,13 [.005]

700 SERIES HOUSINGS

- C2** Standard Mount 5" Pilot End Ports
- C8** Standard Mount 5" Pilot Side Ports
- E2** Standard Mount 125mm Pilot End Ports
- E8** Standard Mount 125mm Pilot Side Ports

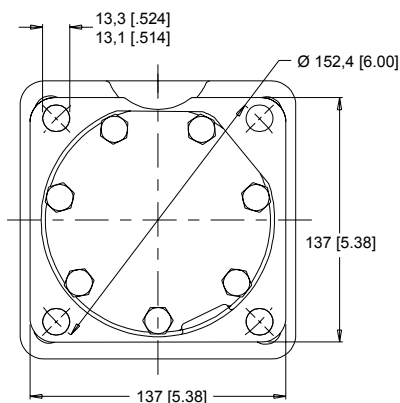
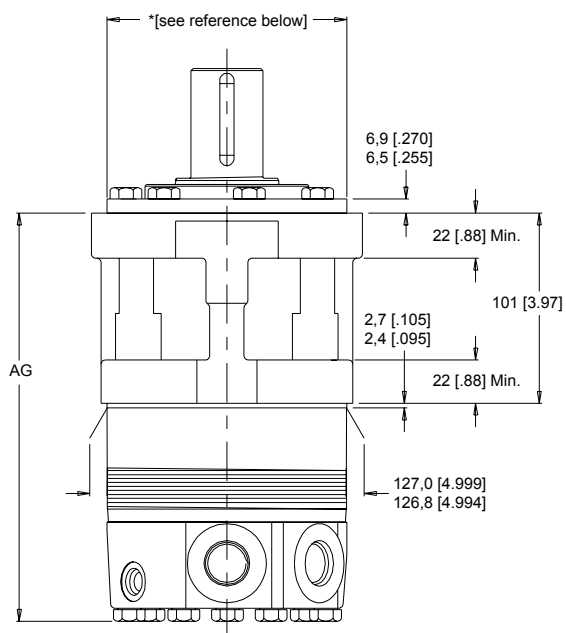
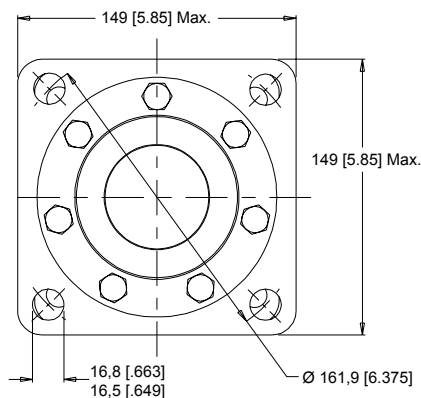

NOTE: *Dimension for the C2 & C8 is 127,0 [5.00] - 127,7 [4.99].
*Dimension for the E2 & E8 is 124,9 [4.92] - 124,5 [4.90].

Bearing Curve: The bearing curve represents allowable bearing loads based on ISO 281 bearing capacity for an L_{10} life of 2,000 hours at 100 rpm. Radial loads for speeds other than 100 rpm may be calculated using the multiplication factor table located below.

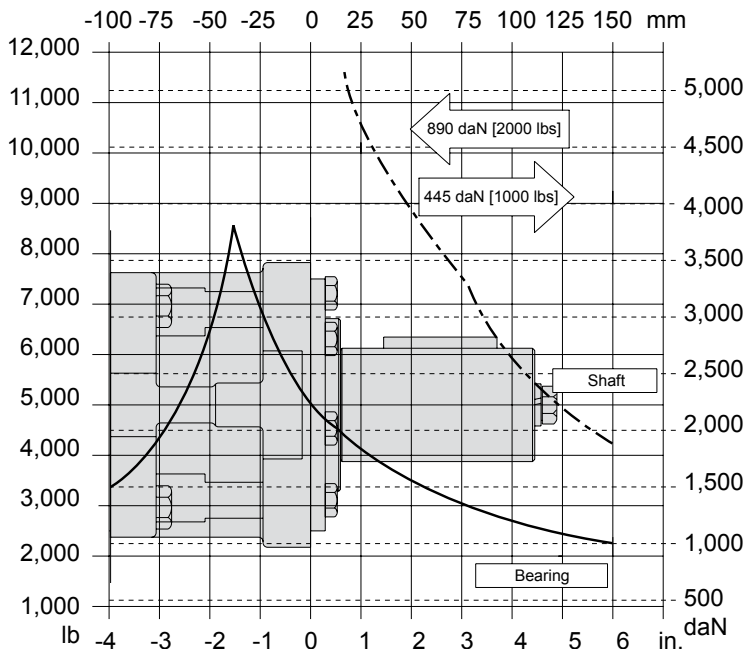

LENGTH / WEIGHT CHART
Standard Mount - Dimension AG

Code	mm [in]	kg [lb]
300	209 [8.25]	20,2 [44.6]
375	216 [8.50]	20,8 [45.8]
470	223 [8.80]	21,4 [47.1]
540	230 [9.04]	21,9 [48.2]
750	248 [9.75]	23,3 [51.3]
930	263 [10.35]	24,4 [53.8]
1K1	273 [10.75]	25,3 [55.7]
1K5	311 [12.25]	28,3 [62.5]
2K1	362 [14.25]	32,3 [71.3]

NOTE: DT motor weights vary $\pm 1,4$ kg [3 lb] depending upon motor configuration. Subtract 3 [.11] from dimension AG for motors using the 1,2 or 5 Endcover.

BEARING LOAD MULTIPLICATION FACTOR TABLE

RPM	FACTOR	RPM	FACTOR
50	1.23	500	0.62
100	1.00	600	0.58
200	0.81	700	0.56
300	0.72	800	0.50
400	0.66		



30 1-1/2" Straight

Max. Torque: 2230 Nm [19800 lb-in]

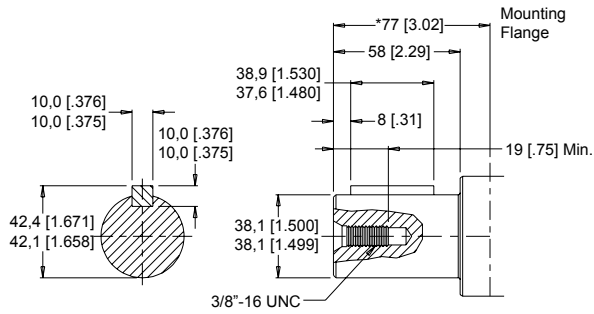

40 2-1/4" Straight

Max. Torque: 2700 Nm [24000 lb-in]

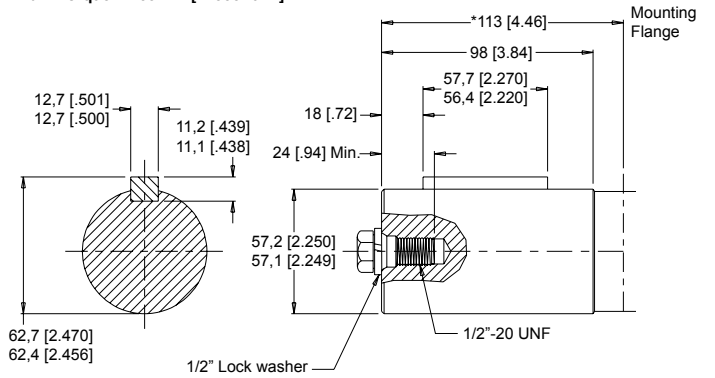

36 40mm Straight

Max. Torque: 2700 Nm [24000 lb-in]

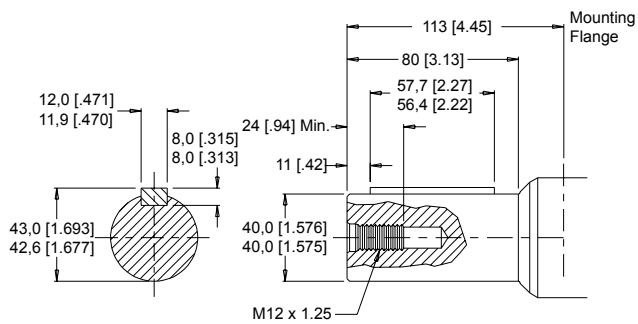

54 40mm Straight Extended

41 50mm Straight

Max. Torque: 2700 Nm [24000 lb-in]

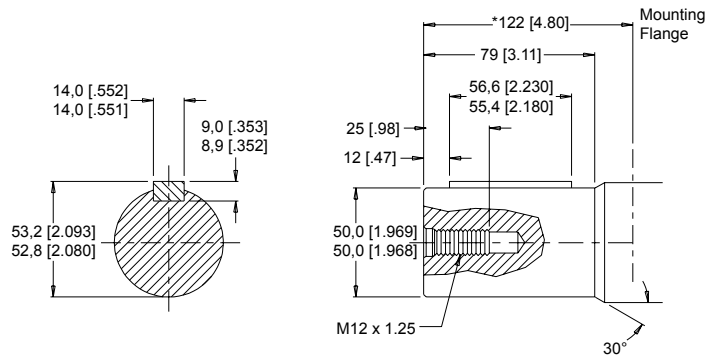

47 2-1/4" Straight with Modified Keyway

Max. Torque: 2700 Nm [24000 lb-in]

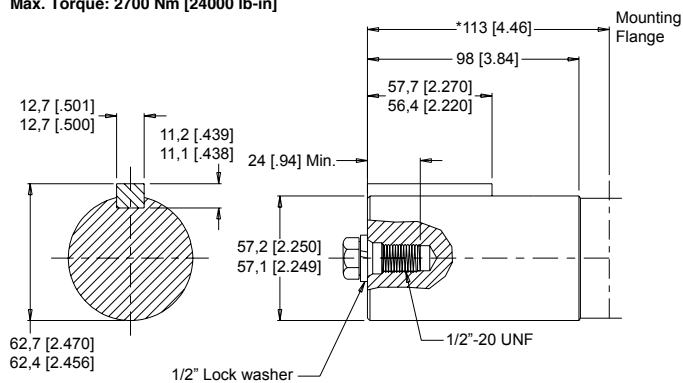

NOTE: *Shaft lengths vary ± 0.8 [0.030]. †For speed sensor motors only.

DT

700 SERIES SHAFTS



31 1-1/2" Tapered

Max. Torque: 2250 Nm [19900 lb-in]

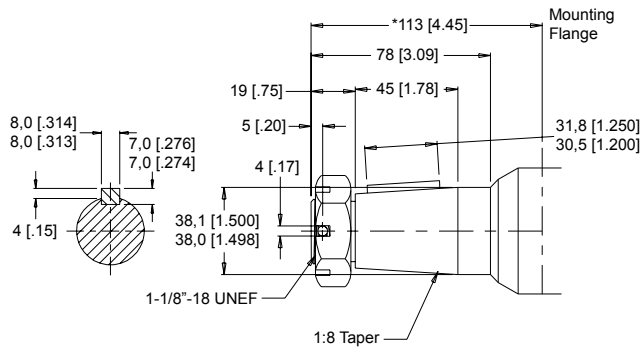

45 60mm Tapered

Max. Torque: 2700 Nm [24000 lb-in]

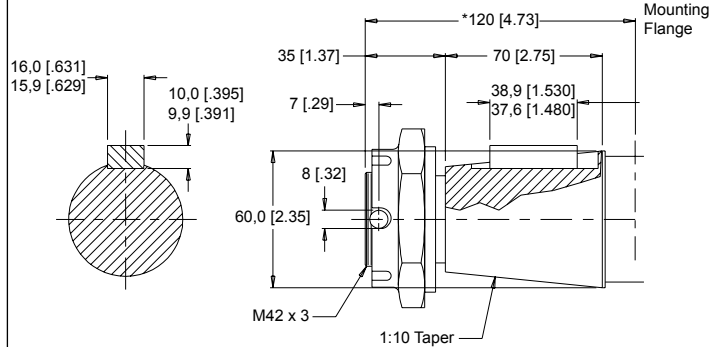

23 14 Tooth Spline

Max. Torque: 2070 Nm [18400 lb-in]

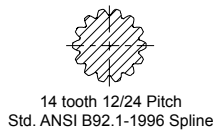

†09 14 Tooth Spline Extended

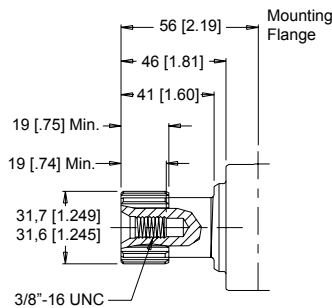

33 17 Tooth Spline

Max. Torque: 2250 Nm [19900 lb-in]

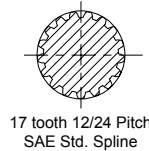

†49 17 Tooth Spline Extended

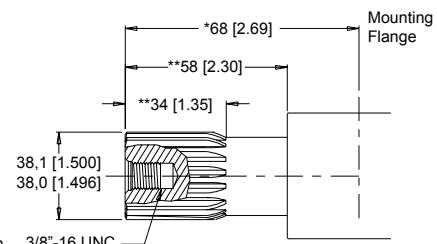

NOTE: **For the 49 shaft add 9,7mm [.38 in] to dimension.

42 16 Tooth Spline

Max. Torque: 2700 Nm [24000 lb-in]

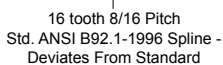

†48 16 Tooth Spline Extended

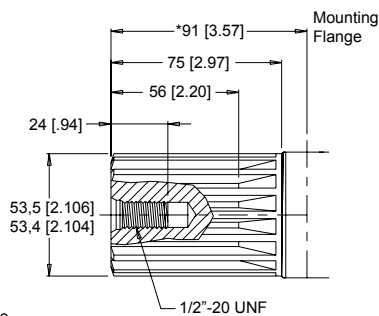

NOTE: A slotted nut is standard on all tapered shafts. *Shaft lengths vary $\pm 0,8$ [.030]. †For speed sensor motors only.



SIDE PORTS

2 3/4" BSP.F with 1/4" Drain

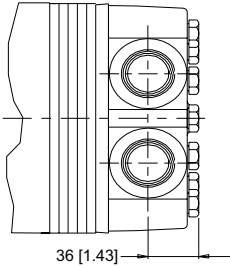

Auxiliary View Q - Case Drain

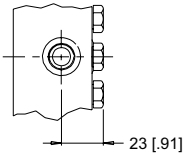

Auxiliary View V - Valve Cavity

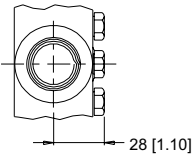

5 1-1/16" O-Ring with 7/16" Drain

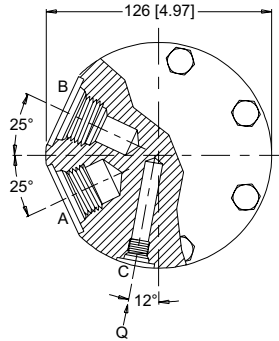

NOTE: Shown with standard case drain.

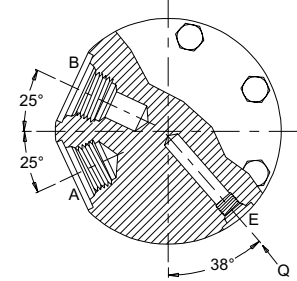

NOTE: Shown with internal drain option.

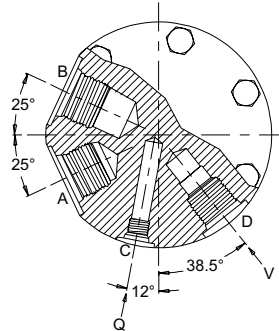

NOTE: Shown with standard case drain & valve cavity.

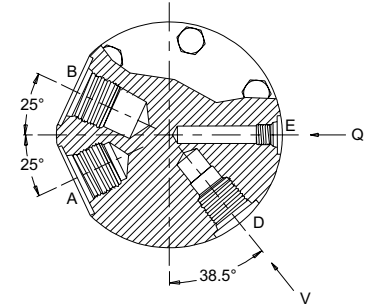

NOTE: Shown with internal drain & valve cavity.

6 1-1/16" O-Ring with 7/16" Drain

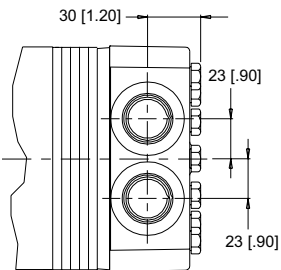

7 3/4" BSP.F with 1/4" Drain

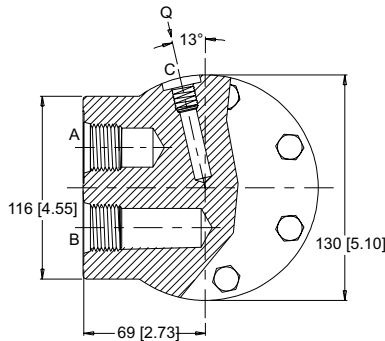

NOTE: Shown with standard case drain.

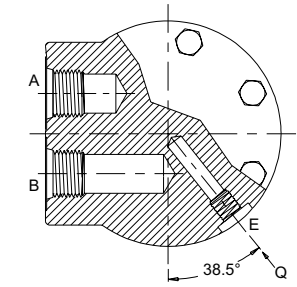

NOTE: Shown with internal drain option.



NOTE: A- Pressure Port B- Pressure Port C- Case Drain
D- 10 Series/2-way Valve Cavity (7/8"-14 UNF-2B)
E- Internal Drain

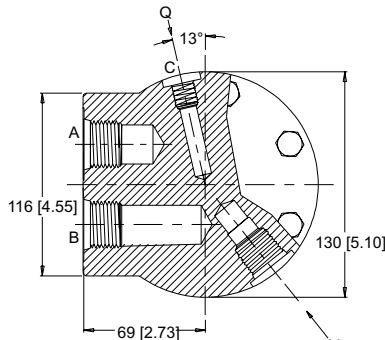

NOTE: Shown with standard case drain & valve cavity.

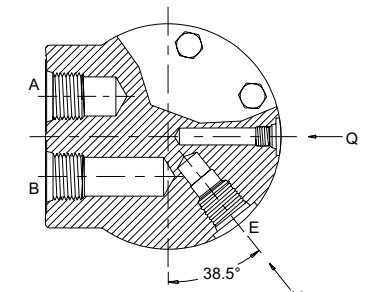

NOTE: Shown with internal drain & valve cavity.

DT



700 SERIES PORTING OPTIONS

SIDE PORTS

3 Manifold with 7/16" Drain

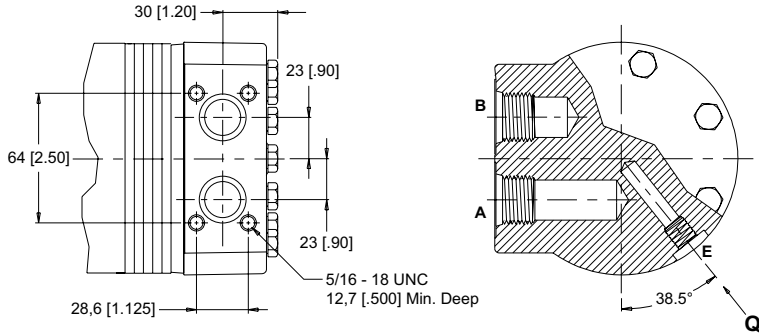

Q - Case Drain

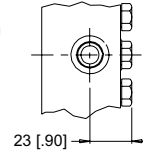

V - Valve Cavity

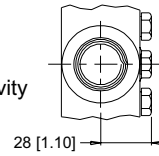

NOTE: The 3 endcover is only available with the internal drain option..

END PORTS

1 7/8" O-Ring with 7/16" Drain

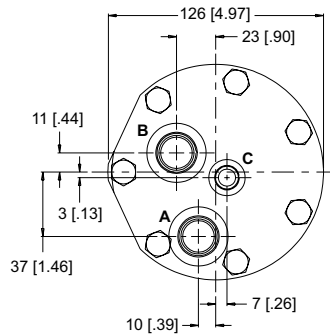
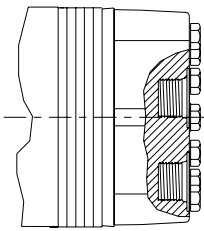

NOTE: Shown with standard case drain.

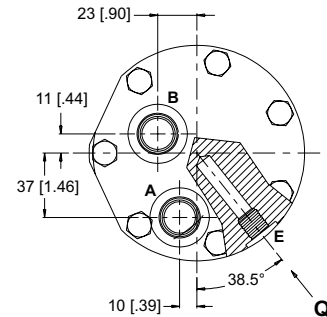

NOTE: Shown with internal drain option.

NOTE: A- Pressure Port B- Pressure Port C- Case Drain
D- 10 Series/2-way Valve Cavity (7/8"-14 UNF-2B)
E- Internal Drain

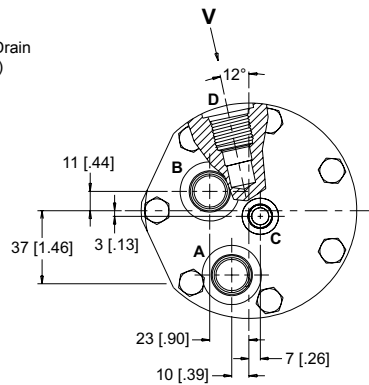

NOTE: Shown with standard case drain & valve cavity.

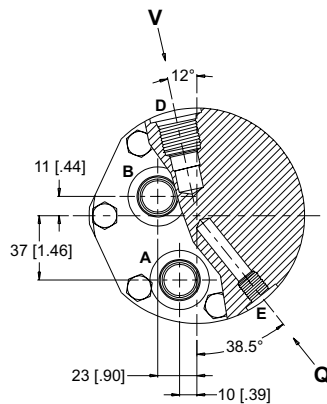

NOTE: Shown with internal drain & valve cavity.



700 SERIES MODEL CODE BUILDER

SERIES	DISPLACEMENT	HOUSING	SHAFT	PAINT	CAVITY	ADD ON	MISCELLANEOUS
STEP 1	STEP 2	STEP 3	STEP 4	STEP 5	STEP 6	STEP 7	STEP 8

STEP 1 - Select a series

700 DT Series Motor

STEP 2 - Select a displacement option

300	300 cc [18.3 in ³ /rev]	930	929 cc [56.7 in ³ /rev]
375	374 cc [22.8 in ³ /rev]	1K1	1047 cc [63.9 in ³ /rev]
470	464 cc [28.3 in ³ /rev]	1K5	1495 cc [91.2 in ³ /rev]
540	536 cc [32.7 in ³ /rev]	2K1	2093 cc [127.7 in ³ /rev]
750	747 cc [45.6 in ³ /rev]		

STEP 3 - Select a mounting option

NOTE: To complete the three (3) digit DT Series housing code a two (2) digit mounting option must be followed with the single (1) digit porting option found in STEP 3 part II. Side port mounting options need side port porting options and end port mounting options need end port porting options.

C2	Standard Mount 5" Pilot End Ports (S)
C8	Standard Mount 5" Pilot Side Ports (S)
E2	Standard Mount 125mm Pilot End Ports (S)
E8	Standard Mount 125mm Pilot Side Ports (S)

STEP 3 (part II) - Select a porting option

END PORTS

1 7/8" O-Ring With 7/16" Drain

SIDE PORTS

2	3/4" BSP.F With 1/4" Drain (Radial Ports)
3	Manifold With 7/16" Drian (Parallel Ports)
5	1-1/16" O-Ring With 7/16" Drain (Radial Ports)
6	1-1/16" O-Ring With 7/16" Drain (Parallel Ports)
7	3/4" BSP.F With 1/4" Drain (Parallel Ports)

STEP 4 - Select a shaft option

30	1-1/2" Straight	41	50mm Straight
31	1-1/2" Tapered	45	60mm Tapered
40	2-1/4" Straight	47	2-1/4" Straight Modified (S)
36	40mm Straight	54	40mm Straight Extended (S)
23	14 Tooth Spline	09	14 Tooth Spline Extended (S)
42	16 Tooth Spline	48	16 Tooth Spline Extended (S)
33	17 Tooth Spline	49	17 Tooth Spline Extended (S)

STEP 5 - Select a paint option

A	Black
B	Black (unpainted flange face)
Z	No Paint

STEP 6 - Select a valve cavity option

A	None
B	Relief Valve Cavity
C	69 Bar [1000 psi] Relief Valve Installed
D	86 Bar [1250 psi] Relief Valve Installed
E	104 Bar [1500 psi] Relief Valve Installed
F	121 Bar [1750 psi] Relief Valve Installed
G	138 Bar [2000 psi] Relief Valve Installed
J	173 Bar [2500 psi] Relief Valve Installed
L	207 Bar [3000 psi] Relief Valve Installed

NOTE: Valve cavity option is not available on porting option 3.

STEP 7 - Select an add on option

A	Standard
B	Lock Nut
C	Solid Hex Nut
W	4-Pin Dual Male Weatherpack Connector (S)
X	4-Pin M12 Dual Male Connector (S)
Y	3-Pin Single Male Weatherpack Connector (S)
Z	4-Pin M12 Single Male Connector (S)

NOTE: (S) - STEP 3 Mountings available for use with speed sensors. STEP 4 Shafts available for use with speed sensors. STEP 7 Speed sensor options.

STEP 8 - Select a miscellaneous option

AA	None
AB	Internal Drain
AC	Freeturning Rotor
AD	Internal Drain with Freeturning Rotor

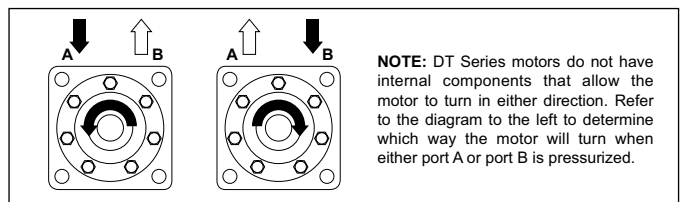



NOTE: Dimensions shown are without paint. Paint thickness can be up to 0,13 [.005]

740 SERIES HOUSINGS

W2 4-Hole End Ports

W8 4-Hole Side Ports

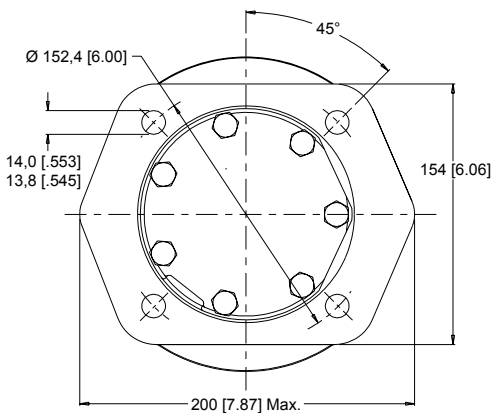
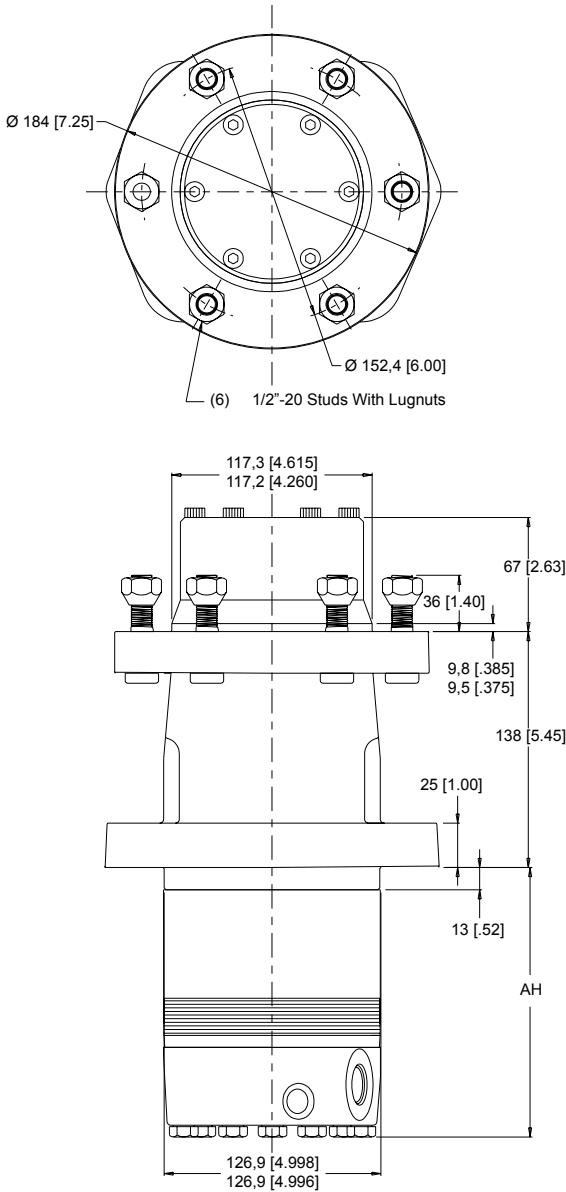

Bearing Curve: The bearing curve represents allowable bearing loads based on ISO 281 bearing capacity for an L_{10} life of 2,000 hours at 100 rpm. Radial loads for speeds other than 100 rpm may be calculated using the multiplication factor table located on page 8.

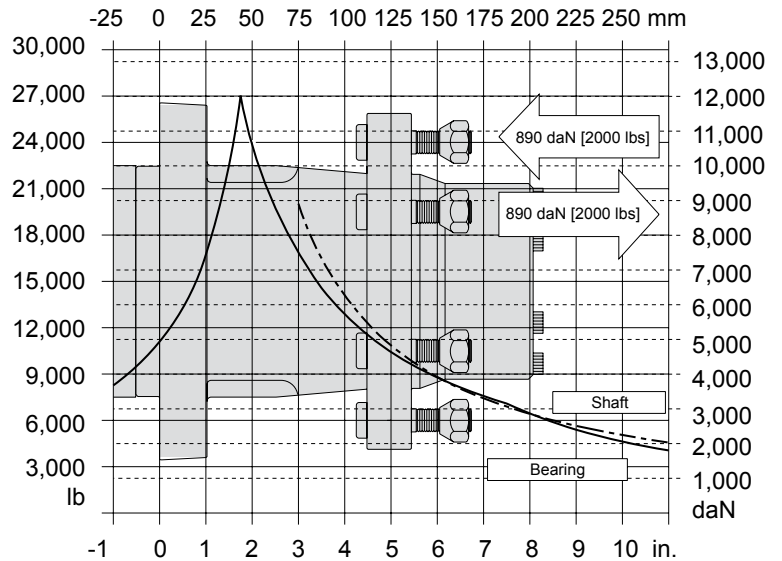

LENGTH / WEIGHT CHART
Wheel Mount - Dimension AH

Code	mm [in]	kg [lb]
300	120 [4.74]	28,4 [62.6]
375	127 [4.99]	28,9 [63.8]
470	134 [5.29]	29,5 [65.1]
540	140 [5.53]	30,0 [66.2]
750	158 [6.24]	31,4 [69.2]
930	174 [6.84]	32,6 [71.8]
1K1	184 [7.24]	33,4 [73.7]
1K5	222 [8.74]	36,5 [80.5]
2K1	273 [10.74]	40,5 [89.3]

NOTE:
DT motor weights vary $\pm 1,4$ kg [3 lb] depending upon motor configuration. Subtract 3 [.11] from dimension AH for motors using the 1,2 or 5 Endcover.

NOTE: The 740 Series motor is not available with the internal drain option. Drain line pressure must be maintained below 2 bar [25 psi]. A dedicated line from the motor drain port to the reservoir is recommended.



740 SERIES MODEL CODE BUILDER

SERIES	DISPLACEMENT	HOUSING	SHAFT	PAINT	CAVITY	ADD ON	MISCELLANEOUS
STEP 1	STEP 2	STEP 3	STEP 4	STEP 5	STEP 6	STEP 7	STEP 8

STEP 1 - Select a series

740 DT Series Wheel Hub Motor

STEP 2 - Select a displacement option

300	300 cc [18.3 in ³ /rev]	930	929 cc [56.7 in ³ /rev]
375	374 cc [22.8 in ³ /rev]	1K1	1047 cc [63.9 in ³ /rev]
470	464 cc [28.3 in ³ /rev]	1K5	1495 cc [91.2 in ³ /rev]
540	536 cc [32.7 in ³ /rev]	2K1	2093 cc [127.7 in ³ /rev]
750	747 cc [45.6 in ³ /rev]		

STEP 3 - Select a mounting option

NOTE: To complete the three (3) digit DT Series housing code a two (2) digit mounting option must be followed with the single (1) digit porting option found in STEP 3 part II. Side port mounting options need side port porting options and end port mounting options need end port porting options.

- W2** 4-Hole End Ports
- W8** 4-Hole Side Ports

STEP 3 (part II) - Select a porting option

END PORTS

1 7/8" O-Ring With 7/16" Drain

SIDE PORTS

- 2** 3/4" BSP.F With 1/4" Drain (Radial Ports)
- 5** 1-1/16" O-Ring With 7/16" Drain (Radial Ports)

STEP 4 - Select a shaft option

61 6-Bolt Wheel Flange

STEP 5 - Select a paint option

- A** Black
- Z** No Paint

STEP 6 - Select a valve cavity option

- A** None
- B** Relief Valve Cavity
- C** 1000 psi Relief Valve Installed
- D** 1250 psi Relief Valve Installed
- E** 1500 psi Relief Valve Installed
- F** 1750 psi Relief Valve Installed
- G** 2000 psi Relief Valve Installed
- J** 2500 psi Relief Valve Installed
- L** 3000 psi Relief Valve Installed

STEP 7 - Select an add on option

- A** Standard

STEP 8 - Select a miscellaneous option

- AA** None
- AC** Freeturning Rotor

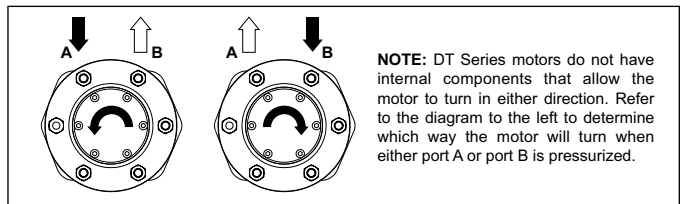



NOTE: Dimensions shown are without paint. Paint thickness can be up to 0,13 [.005]

710 SERIES (DT MOTOR/BRAKE)

W2 4-Hole End Ports

W8 4-Hole Side Ports

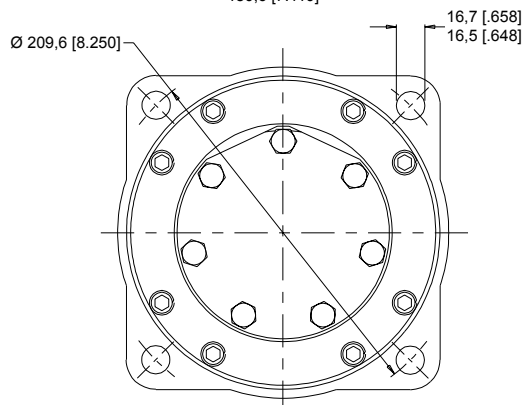
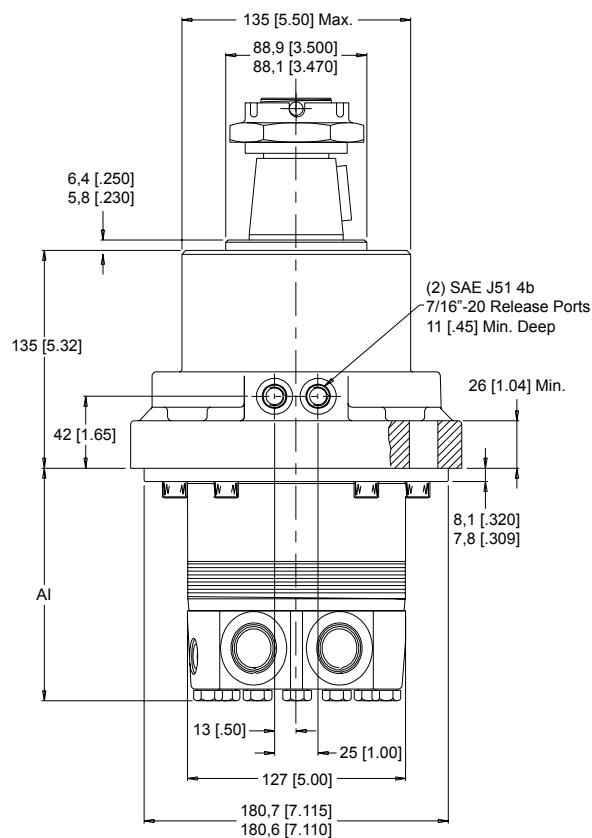
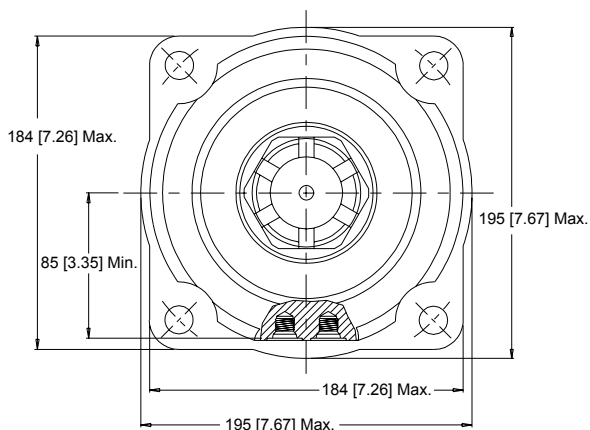

Rated brake torque..... 1582 Nm [14000 lb-in]
 Initial release pressure 19 bar [275 psi]
 Full release pressure 33 bar [475 psi]
 Maximum release pressure 207 bar [3000 psi]
 Release volume..... 13-16 cc [0.8 - 1.0 cu in]

NOTE: See page 18 for important motor/brake operating recommendations.

Bearing Curve: The bearing curve represents allowable bearing loads based on ISO 281 bearing capacity for an L_{10} life of 2,000 hours at 100 rpm. Radial loads for speeds other than 100 rpm may be calculated using the multiplication factor table located on page 8.

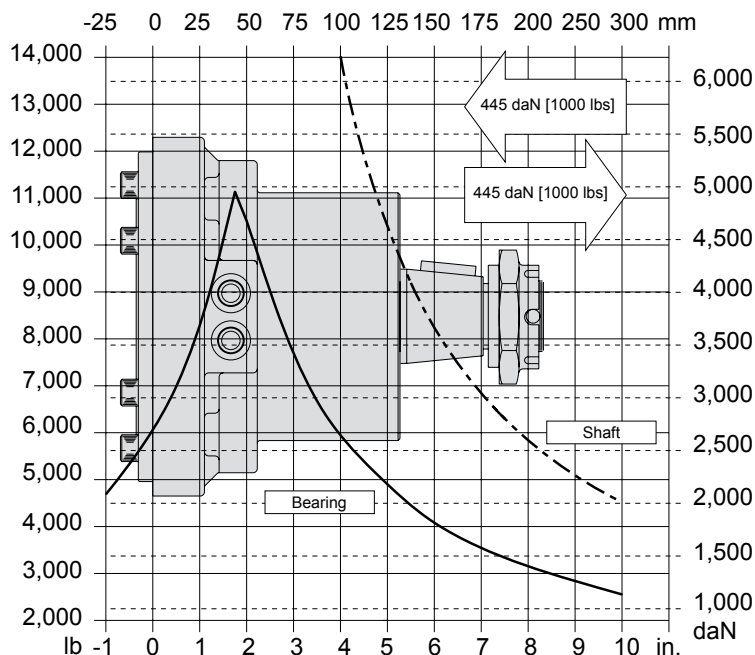

LENGTH / WEIGHT CHART
Wheel Mount - Dimension AI

Code	mm [in]	kg [lb]
300	115 [4.54]	27,2 [60.0]
375	122 [4.79]	27,8 [61.2]
470	129 [5.09]	28,3 [62.5]
540	135 [5.33]	28,8 [63.6]
750	153 [6.04]	30,3 [66.7]
930	169 [6.64]	31,4 [69.2]
1K1	179 [7.04]	32,2 [71.1]
1K5	217 [8.54]	35,3 [77.9]
2K1	268 [10.54]	39,3 [86.7]

NOTE:
DT motor weights vary $\pm 1,4$ kg [3 lb] depending upon motor configuration. Subtract 3 [.11] from dimension AI for motors using the 1,2 or 5 Endcover.

NOTE: The DT 710 series motor/brakes are available with different holding torque specifications. For additional information please contact White Drive Products Customer Service & Technical Support or your local White Drive Products' distributor.



50 2" Straight

Max. Torque: 2700 Nm [24000 lb-in]

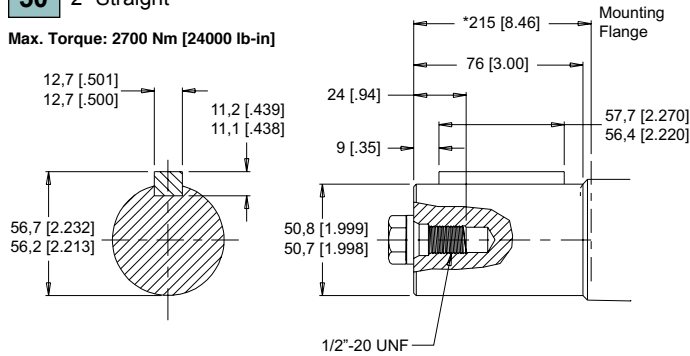

51 55mm Tapered

Max. Torque: 2700 Nm [24000 lb-in]

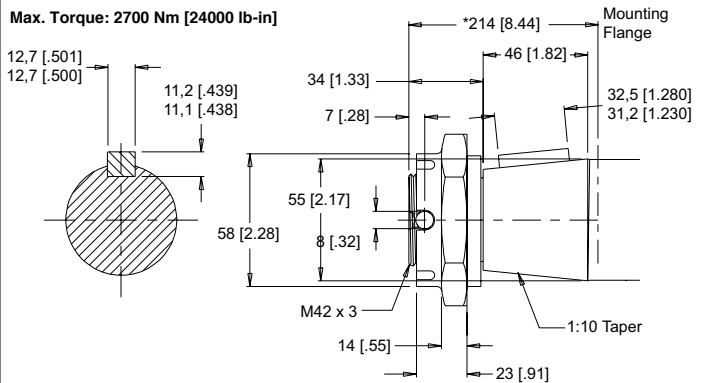

NOTE: A slotted nut is standard on all tapered shafts. *Shaft lengths vary ± 0,8 [.030].

SERIES	DISPLACEMENT	HOUSING	SHAFT	PAINT	CAVITY	ADD ON	MISCELLANEOUS
STEP 1	STEP 2	STEP 3	STEP 4	STEP 5	STEP 6	STEP 7	STEP 8

STEP 1 - Select a series

710 DT Series Motor/Brake

STEP 2 - Select a displacement option

300	300 cc [18.3 in ³ /rev]	930	929 cc [56.7 in ³ /rev]
375	374 cc [22.8 in ³ /rev]	1K1	1047 cc [63.9 in ³ /rev]
470	464 cc [28.3 in ³ /rev]	1K5	1495 cc [91.2 in ³ /rev]
540	536 cc [32.7 in ³ /rev]	2K1	2093 cc [127.7 in ³ /rev]
750	747 cc [45.6 in ³ /rev]		

STEP 3 - Select a mounting option

NOTE: To complete the three (3) digit DT Series housing code a two (2) digit mounting option must be followed with the single (1) digit porting option found in STEP 3 part II. Side port mounting options need side port porting options and end port mounting options need end port porting options.

- W2 4-Hole End Ports
- W8 4-Hole Side Ports

STEP 3 (part II) - Select a porting option

END PORTS

- 1 7/8" O-Ring With 7/16" Drain

SIDE PORTS

- 2 3/4" BSP.F With 1/4" Drain (Radial Ports)
- 3 Manifold With 7/16" Drian (Parallel Ports)
- 5 1-1/16" O-Ring With 7/16" Drain (Radial Ports)
- 6 1-1/16" O-Ring With 7/16" Drain (Parallel Ports)
- 7 3/4" BSP.F With 1/4" Drain (Parallel Ports)

STEP 4 - Select a shaft option

- 50 2" Straight
- 51 55mm Tapered

STEP 5 - Select a paint option

- A Black
- Z No Paint

STEP 6 - Select a valve cavity option

- A None
- B Relief Valve Cavity
- C 1000 psi Relief Valve Installed
- D 1250 psi Relief Valve Installed
- E 1500 psi Relief Valve Installed
- F 1750 psi Relief Valve Installed
- G 2000 psi Relief Valve Installed
- J 2500 psi Relief Valve Installed
- L 3000 psi Relief Valve Installed

NOTE: Valve cavity option is not available on porting option 3.

STEP 7 - Select an add on option

- A Standard

STEP 8 - Select a miscellaneous option

- AA None
- AC Freeturning Rotor

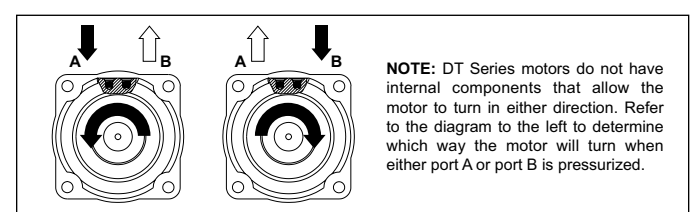

OPERATING AND TECHNICAL INFORMATION

WHITE DRIVE PRODUCT MOTOR/BRAKE PRECAUTION

CAUTION! - White Drive Products' motors/brakes are intended to operate as static or parking brakes. System circuitry must be designed to bring the load to a stop before applying the brake.

CAUTION! - Because it is possible for some large displacement motors to overpower the brake, it is critical that the maximum system pressure be limited for these applications. Failure to do so could cause serious injury or death. When choosing a motor/brake for an application, consult the performance chart for the series and displacement chosen for the application to verify that the maximum operating pressure of the system will not allow the motor to produce more torque than the maximum rating of the brake. Also, it is vital that the system relief be set low enough to insure that the motor is not able to overpower the brake.

To ensure proper operation of the brake, case drain back pressure must be maintained at 34 bar [500 psi] or less. Case drain back pressure above 34 bar [500 psi] can result in erratic operation of the brake. To avoid potential problems with the operation of the brake, a separate case drain line is recommended. Use of the internal drain option is not recommended due to the possibility of return line pressure spikes. A simple schematic of a system utilizing a motor/brake is shown in Figure A below. Although maximum brake release pressure may be used for an application, a 34 bar [500 psi] pressure reducing valve is recommended to promote maximum life for the brake release piston seals. However, if a pressure reducing valve is used in a system which has case drain back pressure, the pressure reducing valve should be set to 34 bar [500 psi] over the expected case pressure to ensure full brake release. To achieve proper brake release operation, it is necessary to bleed out any trapped air and fill brake release cavity and hoses before all connections are tightened. To facilitate this operation, all motor/brakes feature two release ports. One or both of these ports may be used to release the brake in the unit. Motor/brakes should be configured so that the release ports are near the top of the unit in the installed position. Once all system connections are made, one release port must be opened to atmosphere and the brake release line carefully charged with fluid until all air is removed from the line and motor/brake release cavity. When this has been accomplished the port plug or secondary release line must be reinstalled. In the event of a pump or battery failure, an external pressure source may be connected to the brake release port to release the brake, allowing the machine to be moved.

Typical motor/brake schematic

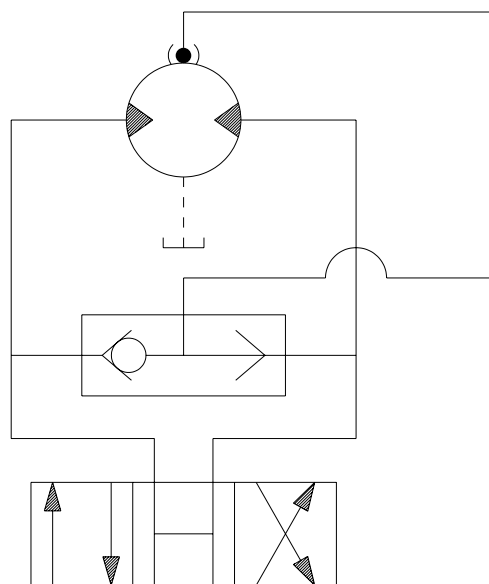

Figure A



NOTE: It is vital that all operating recommendations be followed. Failure to do so could result in injury or death.

Important Information

Before selecting or using a White Drive Products' product, it is important that all information concerning the product warranty, limitation of liability and responsibility of the customer be reviewed. This information is located below. Please direct any questions regarding this information to your White Drive Products representative.

Disclaimer

This catalog provides product options for further investigation by customers having technical expertise with respect to the use of such products. It is the responsibility of the customer to thoroughly analyze all aspects of the customer's application and to review the information concerning the product in the current product catalog. Due to the diversity of possible applications, the customer is solely responsible for making the final selection of the product(s) to be used and to assure that all performance, safety and warning requirements of the application are met. The customer is further responsible for all testing to verify acceptable life and performance of White Drive Products' products under actual operating conditions.

White Drive Products has made all reasonable efforts to present accurate information in this catalog and shall not be responsible for any incorrect information which may result from unintentional oversight. Due to continuous product improvement, the product specifications as stated in this catalog are subject to change by White Drive Products at any time without notice. The customer should consult a sales representative of White Drive Products for detailed information and to determine any changes in the information in this catalog.

Improper selection or improper use of the products described herein can result in death, personal injury and/or property damage. White Drive Products, Inc.'s sole responsibility with respect to its products is set forth in the warranty/limitation of liability policy state herein.

Warranty

White Drive Products' products are sold subject to a limited warranty and a limitation of remedies policy, both of which constitute part of any and all agreements to purchase White Drive Products' products. White Drive Products makes no other warranties or promises other than those specifically noted in its written policies, and no White Drive Products employee or agent has the power to alter those policies other than in writing.

OTHER FINE PRODUCTS AVAILABLE FROM WHITE DRIVE PRODUCTS



**A COMPLETE RANGE
OF LSHT HYDRAULIC
MOTORS**



**HYDRAULIC
CONTROLLED
PRESSURE
RELEASED BRAKES**



Delivering The Power To Get Work Done.

United States

White Drive Products, Inc.
P.O. Box 1127
Hopkinsville, KY. USA 42241
Phone: +1.270.885.1110
Fax: +1.270.886.8462
infousa@whitedriveproducts.com

Germany

White Drive Products GmbH
Halskestrasse 15
D-40880 Ratingen, Germany
Phone: +49 2102-1237770
Fax: +49 2102-1237779
infoeu@whitedriveproducts.com

China

White (China) Drive Products Co., Ltd.
1-8 Ning Zhen Gong Lu
Zhenjiang, 212021, Jiangsu, China
Phone: +86 511 5729988
Fax: +86 511 5728921
infochina@whitedriveproducts.com



whitedriveproducts

www.whitedriveproducts.com